

# Instructions For Use

## Optima L-XP Series

### Preparative Ultracentrifuges

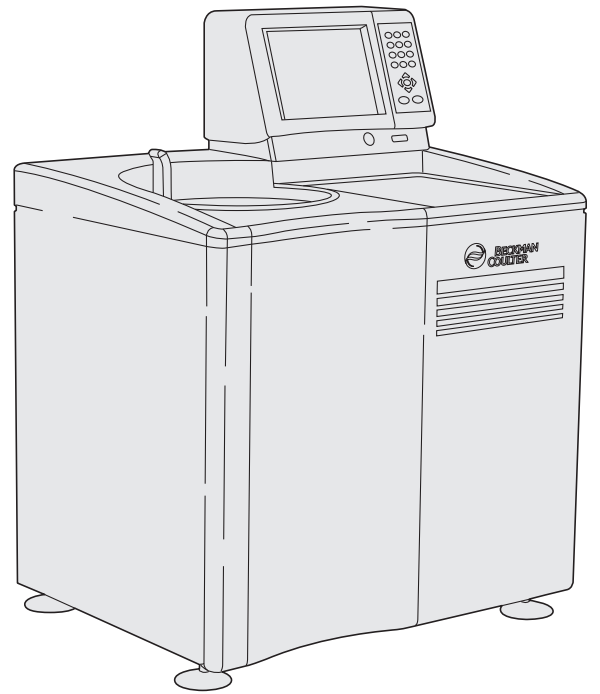

PN LXP-IM-7AB  
October 2013



Beckman Coulter, Inc.  
250 S. Kraemer Blvd.  
Brea, CA 92821 U.S.A.



**Optima L-XP Series**  
**Preparative Ultracentrifuges**  
PN LXP-IM-7AB (October 2013)

Copyright ©2002–2013 Beckman Coulter, Inc.  
All rights reserved

No part of this document may be reproduced or transmitted in any form or by any means, electronic, mechanical, photocopying, recording, or otherwise, without prior written permission from Beckman Coulter, Inc.

Beckman Coulter, the stylized logo, and Quick-Seal are trademarks of Beckman Coulter, Inc. and are registered in the USPTO.

All other trademarks, service marks, products, or services are trademarks or registered trademarks of their respective holders.

Find us on the World Wide Web at:  
[www.beckmancoulter.com](http://www.beckmancoulter.com)

Made in U.S.A.  
Printed in U.S.A.

# Safety Notice

Read all product manuals and consult with Beckman Coulter-trained personnel before attempting to operate the instrument. Do not attempt to perform any procedure before carefully reading all instructions. Always follow product labeling and manufacturer's recommendations. If in doubt as to how to proceed in any situation, contact your Beckman Coulter Representative.

## Alerts for Warning, Caution, Important, and Note

---

### **WARNING**

**WARNING** indicates a potentially hazardous situation which, if not avoided, could result in death or serious injury.

### **CAUTION**

**CAUTION** indicates a potentially hazardous situation, which, if not avoided, may result in minor or moderate injury. It may also be used to alert against unsafe practices.

**IMPORTANT** IMPORTANT is used for comments that add value to the step or procedure being performed. Following the advice in the Important adds benefit to the performance of a piece of equipment or to a process.

**NOTE** NOTE is used to call attention to notable information that should be followed during installation, use, or servicing of this equipment.

## Safety During Installation and/or Maintenance

---

This instrument is designed to be installed by a Beckman Coulter Field Service representative. Installation by anyone other than authorized Beckman Coulter personnel invalidates any warranty covering the instrument. Also, if the instrument needs to be moved, a Beckman Coulter Field Service representative must reinstall and relevel the instrument in its new location.

Any servicing of this equipment that requires removal of any covers can expose parts which involve the risk of electric shock or personal injury. Make sure that the power switch is turned off and the instrument is disconnected from the main power source by removing the Mains (power) plug from the outlet receptacle, and refer such servicing to qualified personnel.

Do not replace any ultracentrifuge components with parts not specified for use on this instrument.

## Electrical Safety

---

To reduce the risk of electrical shock, this instrument uses a three-wire electrical cord and plug to connect this equipment to earth-ground. Make sure that the matching wall outlet receptacle is properly wired and earth-grounded.

Do not place containers holding liquid on or near the chamber door. If they spill, liquid may get into the instrument and damage electrical or mechanical components.

## Safety Against Risk of Fire

---

Fuses protect certain electrical circuits within this instrument against overcurrent conditions. For conditioned protection against the risk of fire, replace only with the same type and rating specified.

This instrument is not designed for use with materials capable of developing flammable or explosive vapors or hazardous chemical reactions. Do not centrifuge such materials (for example, chloroform or ethyl alcohol) in this instrument nor handle or store them near the centrifuge.

## Mechanical Safety

---

For safe operation of the equipment, observe the following:

- Use only the Beckman Coulter rotors and accessories designed for use in this instrument.
- Do not exceed the maximum rated speed of the rotor in use.
- NEVER attempt to slow or stop a rotor by hand.
- Do not move the ultracentrifuge while the drive motor is spinning.
- In the event of a power failure, do not attempt to retrieve the sample from the instrument for at least one hour. Then follow the instructions for recovery of the sample under [CHAPTER 5, Troubleshooting](#).

## Chemical and Biological Safety

---

Normal operation may involve the use of solutions and test samples that are pathogenic, toxic, or radioactive. Such materials should not be used in this instrument unless *all necessary safety precautions are taken*.



**WARNING**

Normal operation may involve the use of solutions and test samples that are pathogenic, toxic, or radioactive. Handle body fluids with care because they can transmit disease. No known test offers complete assurance that they are free of micro-organisms. Some of the most virulent—Hepatitis (B and C) and HIV (I-V) viruses, atypical mycobacteria, and certain systemic fungi—further emphasize the need for aerosol protection. Handle other infectious samples according to good laboratory procedures and methods to prevent spread of disease. Because spills may generate aerosols, observe proper safety precautions for aerosol containment. Do not run toxic, pathogenic, or radioactive materials in this ultracentrifuge without taking appropriate safety precautions. Biosafe containment should be used when Risk Group II materials (as identified in the World Health Organization *Laboratory Biosafety Manual* are handled; materials of a higher group require more than one level of protection.



**WARNING**

Do not use the ultracentrifuge in the vicinity of flammable liquids or vapors, and do not run such materials in the instrument. Do not lean on the instrument or place items on it while it is operating.

It is your responsibility to decontaminate the instrument and accessories before requesting service by Beckman Coulter Field Service.



# Contents

## Safety Notice, iii

Alerts for Warning, Caution, Important, and Note, iii

Safety During Installation and/or Maintenance, iii

Electrical Safety, iv

Safety Against Risk of Fire, iv

Mechanical Safety, iv

Chemical and Biological Safety, iv

## Introduction, xv

Certification, xv

Scope of Manual, xv

CFC-Free Centrifugation, xvi

Recycling Label, xvi

RoHS Notice, xvi

Software Copyright, xvii

## **CHAPTER 1:** Description, 1-1

Introduction, 1-1

Instrument Function, 1-1

Safety Features, 1-2

Door, 1-2

Barrier Ring, 1-2

Imbalance Detector, 1-2

Overspeed System, 1-2

Dynamic Rotor Inertia Check (DRIC), 1-3

Instrument Chassis, 1-3

Rotor Chamber, 1-3

Vacuum System, 1-3

Drive, 1-3

Temperature Sensing and Control, 1-4

Name Rating Plate, 1-4

Controls and Indicators, 1-4

Power, 1-4

Key Switch Positions, 1-5

Control Panel, 1-5

Specifications, 1-9

Available Rotors, 1-10

## **CHAPTER 2: Operation, 2-1**

Introduction, 2-1

Power, 2-1

Key Switch Positions, 2-1

Normal Position, 2-2

Locked Position, 2-2

Zonal Position, 2-2

Touchscreen Interface, 2-2

Basic Operation, 2-3

Logging In, 2-4

System-Level Operations, 2-5

Adding a User, 2-6

Copying Users, 2-8

Set PIN Number, 2-9

Set Role, 2-10

Removing Users, 2-10

Require User Login, 2-11

Required Rotor Selection, 2-11

Enable Run Comment, 2-12

Manual Operation, 2-12

Programmed Operation, 2-15

Step Program, 2-17

RPM to RCF Toggle, 2-19

RCF Conversion, 2-19

w2t, 2-20

Rotor Conversion, 2-22

Auto Pelleting, 2-23

Auto Rate Zonal, 2-24

Recall Program, 2-26

Remote Operation, 2-26

Using Calculation Features, 2-27

Pelleting Time Calculation, 2-27

Concentration Measures, 2-28

Refractive Index/Density, 2-29

Speed Reduction for Dense Solutions, 2-29



Speed Reduction for Precipitating Solutions, 2-30  
Sedimentation Coefficient from Run Data, 2-31  
Sedimentation Coefficient From Molecular Mass, 2-32

Restore Windows, 2-33

### **CHAPTER 3: Simulations, 3-1**

Using Simulation Features, 3-1

ESP Pelleting, 3-1

ESP Rate Zonal, 3-3

ESP Plasmid Run, 3-4

ESP RNA (BEST), 3-6

ESP RNA (Fast), 3-7

Recall Simulation, 3-9

### **CHAPTER 4: Reference and Log Functions, 4-1**

Reference Features, 4-1

    Rotor Catalog, 4-1

    Rotor Library, 4-3

    Tube Catalog, 4-5

    Chemical Resistances, 4-6

Exporting Data, 4-8

Log Features, 4-10

    Instrument Usage Log, 4-10

    Display Last Run Record, 4-10

### **CHAPTER 5: Troubleshooting, 5-1**

Introduction, 5-1

User Messages, 5-1

Retrieving Your Sample in Case of Power Failure, 5-3

### **CHAPTER 6: Care and Maintenance, 6-1**

Introduction, 6-1

Cleaning, 6-1

    Rotor Chamber, 6-1

Decontamination, 6-2

Sterilization and Disinfection, 6-2

Storage and Transportation, 6-2

Supply List, 6-3

    Replacement Parts, 6-3

    Supplies, 6-3

**APPENDIX A: Preinstallation Requirements, A-1**

Introduction, A-1

Space Requirements, A-1

Bio-Safety Level 3 Installation, A-2

Electrical Requirements, A-2

Attaching a Printer, A-3

**APPENDIX B: Remote Access, B-1**

Introduction, B-1

VNC License Information, B-2

GNU General Public License, Version 2, June 1991, B-3

Preamble, B-3

GNU General Public License Terms and Conditions for Copying,  
Distribution and Modification, B-4

Beckman Coulter, Inc.

Optima L, LE, L-XP, and XL

Preparative Ultracentrifuges Warranty

Related Documents

# Illustrations

- 1.1 Optima L-XP Control Head, 1-5
- 1.2 Key Switch Positions, 1-5
- 1.3 Control Panel, 1-6
- 1.4 Settings Screen, 1-6
- 1.5 Step Program Screen, 1-7
- 2.1 Key Switch Positions, 2-1
- 2.2 Touchscreen and Keypad Operation, 2-3
- 2.3 User Login Screen, 2-5
- 2.4 System Management Screen, 2-6
- 2.5 Add User Screen, 2-6
- 2.6 New PIN Screen, 2-7
- 2.7 Confirm PIN Screen, 2-7
- 2.8 Set Role Screen, 2-8
- 2.9 Enable User Login Option, 2-11
- 2.10 Settings Screen, 2-12
- 2.11 Delay Start Screen, 2-14
- 2.12 Precool/Heat Temperature Screen, 2-15
- 2.13 Setup Menu, 2-16
- 2.14 File Types, 2-16
- 2.15 Step Program Screen, 2-17
- 2.16 Save As Dialog, 2-18
- 2.17 RCF Run Screen, 2-19
- 2.18 w2t Run Screen, 2-21
- 2.19 Substitute Rotor Screen, 2-22
- 2.20 Auto Pelleting Run Screen, 2-24
- 2.21 Auto Rate Zonal Screen, 2-25
- 2.22 Open File Dialog, 2-26
- 2.23 Calculate Menu, 2-27
- 2.24 Calculate Pelleting Time Screen, 2-27
- 2.25 Calculate Concentration Measures Screen, 2-28
- 2.26 Calculate Refractive Index/Density Screen, 2-29
- 2.27 Calculate Reduced Rotor Speed for Dense Solutions Screen, 2-30
- 2.28 Calculate Reduced Rotor Speed for Precipitating Solutions Screen, 2-31

2.29	Calculate Sedimentation Coefficient from Run Data Screen, 2-32
2.30	Estimate Sedimentation Coefficient from Molecular Mass Screen, 2-33
3.1	Simulate Menu, 3-1
3.2	ESP Pelleting Screen, 3-2
3.3	ESP Rate Zonal Screen, 3-3
3.4	ESP Plasmid Run Screen, 3-5
3.5	ESP RNA (Best) Screen, 3-6
3.6	ESP RNA (Fast) Screen, 3-8
4.1	Reference Menu, 4-1
4.2	Rotor Catalog Screen, 4-2
4.3	Selected Rotor Specifications, 4-3
4.4	Select Rotor Screen, 4-3
4.5	Enter Rotor Serial Number Screen, 4-4
4.6	Tube Catalog, 4-5
4.7	Selected Tube Specifications, 4-6
4.8	Chemicals/UPAC Name Screen, 4-7
4.9	Chemical Resistances Screen, 4-8
4.10	Optima L-XP Control Head with USB Hub, 4-9
4.11	Export Data Screen, 4-9
4.12	Logs Menu, 4-10
4.13	Run Record, 4-11
5.1	Removing the Control Head Cover, 5-4
5.2	Depressing the Latch to Loosen the Front Panel, 5-5
5.3	Interior View of Instrument (Panel Removed), 5-5
5.4	Reinstalling the Front Panel, 5-6
A.1	Dimensions of the Optima L-XP Ultracentrifuge, A-2
A.2	Electrical Connection, A-3
A.3	Printer Connection, A-4
B.1	About Optima L-XP Screen, B-2

# Tables

1.1	<a href="#">Step Program Screen Features</a> , 1-7
2.1	<a href="#">Acceleration and Deceleration Profiles</a> , 2-14
5.1	<a href="#">Diagnostic Message Chart</a> , 5-2
A.1	<a href="#">Required Wire Connections</a> , A-3



## Certification

---

Beckman Coulter Optima L-XP series ultracentrifuges are manufactured in a facility that maintains certifications to both ISO 9001:2008 and ISO 13485:2003. They have been designed and tested to be compliant (when used with Beckman Coulter rotors) with the laboratory equipment requirements of applicable regulatory agencies. Declarations of conformity and certificates of compliance are available at [www.beckmancoulter.com](http://www.beckmancoulter.com).

## Scope of Manual

---

This manual is designed to familiarize you with the Optima L-XP series ultracentrifuge, its functions, specifications, operation, and routine operator care and maintenance. Beckman Coulter recommends that you read this entire manual, especially the [Safety Notice](#) and all safety-related information, before operating the ultracentrifuge or performing instrument maintenance.

- [CHAPTER 1, Description](#) contains system specifications and a brief physical and functional description of the ultracentrifuge, including the operating controls and indicators.
- [CHAPTER 2, Operation](#) contains ultracentrifuge operating procedures.
- [CHAPTER 3, Simulations](#) describes the use of the run simulation features.
- [CHAPTER 4, Reference and Log Functions](#) provides information about reference and log functions of the ultracentrifuge.
- [CHAPTER 5, Troubleshooting](#) lists possible malfunctions, together with probable causes and suggested corrective actions.
- [CHAPTER 6, Care and Maintenance](#) contains procedures for routine operator care and maintenance, as well as a brief list of supplies and replacement parts.
- [APPENDIX A, Preinstallation Requirements](#) provides information about space and power requirements for installing and connecting the ultracentrifuge.
- [APPENDIX B, Remote Access](#) contains information on how to access the remote access feature.

**NOTE** If the ultracentrifuge is used in a manner other than specified in this manual, the safety and performance of this equipment could be impaired. Further, the use of any equipment other than that recommended by Beckman Coulter has not been evaluated for safety. Use of any equipment not specifically recommended in this manual and/or the appropriate rotor manual is the sole responsibility of the user.

## CFC-Free Centrifugation

---

To ensure minimal environmental impact, no CFCs are used in the manufacture or operation of the Optima L-XP ultracentrifuge.

## Recycling Label

---



This symbol is required in accordance with the Waste Electrical and Electronic Equipment (WEEE) Directive of the European Union. The presence of this marking on the product indicates:

1. The device was put on the European market after August 13, 2005 and
2. The device is not to be disposed via the municipal waste collection system of any member state of the European Union.

It is very important that customers understand and follow all laws regarding the proper decontamination and safe disposal of electrical equipment. For Beckman Coulter products bearing this label please contact your dealer or local Beckman Coulter office for details on the take back program that will facilitate the proper collection, treatment, recovery, recycling and safe disposal of the device.

## RoHS Notice

---

These labels and materials declaration table (the Table of Hazardous Substance's Name and Concentration) are to meet People's Republic of China Electronic Industry Standard SJ/T11364-2006 "Marking for Control of Pollution Caused by Electronic Information Products" requirements.



**China RoHS Caution Label** — This label indicates that the electronic information product contains certain toxic or hazardous substances. The center number is the Environmentally Friendly Use Period (EFUP) date, and indicates the number of calendar years the product can be in operation. Upon the expiration of the EFUP, the product must be immediately recycled. The circling arrows



indicate the product is recyclable. The date code on the label or product indicates the date of manufacture.



**China RoHS Environmental Label** — This label indicates that the electronic information product does not contain any toxic or hazardous substances. The center “e” indicates the product is environmentally safe and does not have an Environmentally Friendly Use Period (EFUP) date. Therefore, it can safely be used indefinitely. The circling arrows indicate the product is recyclable. The date code on the label or product indicates the date of manufacture.

## Software Copyright

---

The Optima L-XP eXPert operating software (a Microsoft Windows-based computer program) is protected by international copyright laws. Unauthorized copying, use, distribution, transfer, or sale is a violation of those laws that may result in civil or criminal penalties. This computer program is also subject to additional restrictions contained in the following Microsoft OEM Customer License Agreement for Embedded Systems:

“If you use the Device to access or utilize the services or functionality of Microsoft Windows XP Server (all editions), or use the Device to permit workstation or computing devices to access or utilize the services or functionality of Microsoft Windows XP Server, you may be required to obtain a Client Access License for the Device and/or each such workstation or computing device. Please refer to the End-User License Agreement for Microsoft Windows XP Server for additional information.”

(The End-User License Agreement is available is available on the Microsoft Embedded Systems Web site.)



# Description

## Introduction

---

*This section describes the Optima L-XP series ultracentrifuge components and their functions. It also describes system safety features and centrifuge controls and displays. Refer to the applicable rotor manual for rotor descriptions.*

## Instrument Function

---

The Optima L-XP ultracentrifuge is used to generate centrifugal forces for the separation of particles. The Optima L-100 XP has a maximum rotational speed of 100,000 RPM; the L-80 XP runs up to 80,000 RPM. Classified S, it can be used with all currently manufactured Beckman Coulter preparative rotors.

The microprocessor-controlled Optima L-XP provides an interactive operator interface, using a touchscreen and keypad, with the eXPert operating software.

Both manual and programmed operation are available. In manual operation, you enter the individual run parameters and begin the run. In programmed operation, you can create, save, recall, modify, and/or print a program, and then automatically run the ultracentrifuge via the program. Several advanced capabilities simplify laboratory ultracentrifugation, such as:

- Setting up a run by specifying RCF (relative centrifugal force),  $w^2t$  (accumulated centrifugal effect), substitute rotor and tube combination, or sedimentation coefficient
- Performing various centrifugation-related calculations, including pelleting time, concentration measures, refractive index, speed reduction, and sedimentation coefficient
- ESP (Efficient Sedimentation Program), a simulation that provides optimum run times using precipitating and non-precipitating media
- Rotor and tube catalogs containing pertinent information about Beckman Coulter ultracentrifuge rotors and tubes
- A rotor library for tracking the rotors in your lab
- Run logs for record-keeping or lab procedures purposes
- Information on compatibility between centrifugation accessories and a variety of chemicals

To enable printing of run parameters, program settings, and/or simulations, a parallel port on the back of the instrument control head allows connection to a printer. See [APPENDIX A, \*Preinstallation Requirements\*](#) for printer availability and hookup procedures.

## Safety Features

---

The Optima L-XP ultracentrifuge has been designed and tested to operate safely indoors at altitudes up to 2000 m (6562 ft).

### Door

The high-strength structural steel chamber door has a solenoid interlock to prevent operator contact with a spinning rotor. When the door is closed it locks automatically. It can be opened only when the power is on and the rotor is at rest with the chamber at atmospheric pressure. If there is a power failure, the door lock can be manually tripped for sample recovery (see [CHAPTER 5, \*Troubleshooting\*](#)).

### Barrier Ring

A 41-mm (1.63-in.) steel alloy armor ring acts as the primary barrier, surrounded by a 13-mm (0.5-in.) vacuum chamber to provide full protection for the operator.

### Imbalance Detector

An imbalance detector monitors the rotor during the run, causing automatic shutdown if rotor loads are severely out of balance. At low speeds, an incorrectly loaded rotor can cause an imbalance.

### Overspeed System

The overspeed system is a safety feature designed to ensure that the rotor does not exceed its maximum allowable speed. This system includes a photoelectric device in the rotor chamber next to the drive spindle and an overspeed disk on the bottom of the rotor. Individual rotor manuals provide information on the correct overspeed disks to be used with each rotor.

The overspeed disk has alternating light and dark sectors. As the rotor spins, the passage of reflecting and nonreflecting sectors over the photoelectric device generates a series of pulses that are detected by the electronic circuitry and software.

After the rotor reaches 1000 RPM, the set speed is checked against the overspeed disk. If the set speed is greater than the maximum speed permitted by the disk, the speed setting is automatically lowered to the disk's maximum speed, but the run continues without interruption. An error message is displayed to alert you to the change.

## Dynamic Rotor Inertia Check (DRIC)

As the rotor accelerates between 15,000 and 20,000 RPM, rotor inertia is measured and the rotor energy is calculated for the speed set by the user. If the calculated rotor energy is determined to be excessive, the instrument recalculates a permitted set speed and uses this value to avoid possible rotor damage. A diagnostic message is displayed to indicate the change.

## Instrument Chassis

---

### Rotor Chamber

The chamber door is made of high-strength structural steel. A solenoid interlock prevents it from being opened during operation. The door can be opened only if the power is on and the vacuum is off, with the chamber at atmospheric pressure. See [CHAPTER 5, Troubleshooting](#) for instructions on accessing the chamber to retrieve your sample in case of a power outage.

### Vacuum System

The Optima L-XP uses a diffusion pump in series with a mechanical vacuum pump to reduce chamber pressure to below 5 microns (0.7 Pa). The system is automatically activated when **Enter** and **Start** are pressed, or may be turned on directly by pressing **Vacuum**, if the chamber door is closed. The vacuum system is also automatically activated when precooling or preheating of the rotor is selected. (When the rotor is at rest, the instrument maintains a partial vacuum.) When the vacuum system is on, the chamber pressure is displayed in microns in the Status window.

At the end of a run, the chamber vacuum must be vented (by pressing **Vacuum** on the keypad) before the door can be opened. (The vacuum cannot be turned off when the rotor is spinning faster than 3000 RPM. If the key is pressed, an error message will appear.) After the door is opened, the chamber returns to approximate room temperature to minimize condensation collecting in the chamber. To help keep the chamber dry and clean, keep the door closed whenever possible.

In zonal operation, the door may be kept open while the rotor is spinning up to 3000 RPM. The vacuum system is activated when the door is closed (after loading the rotor) and can be vented before the rotor is unloaded, while the rotor is still spinning at up to 3000 RPM.

### Drive

The frequency-controlled, air-cooled, direct-drive induction motor requires no gears or brushes. In addition, the drive does not require an oil vacuum seal, external oil reservoir, or continuously operating damper. Externally cooled by forced air and internally cooled by oil, the drive delivers ultra-smooth, quiet performance, with high rotor-imbalance tolerance.

## Temperature Sensing and Control

*Rotor* temperature is monitored by a radiometer mounted in the bottom of the rotor chamber when the chamber pressure is below 100 microns. Above 100 microns, *chamber* temperature is measured by a thermistor mounted in the chamber. (If the radiometer fails, a diagnostic message appears and the system reverts to control by the thermistor; the run will continue.)

The Optima L-XP uses a solid state thermoelectric refrigeration and heating system. Neither coolant nor water is needed; cooling is provided by forced air from the fans.

When the power is on, the temperature control system activates when the door is closed and the vacuum system is turned on. The displayed rotor temperature is controlled to  $\pm 0.3^{\circ}\text{C}$  of the set value.

Run temperature can be set at 0 to 40°C.

## Name Rating Plate

---

A name rating plate is affixed to the rear of the instrument. Check that the line voltage agrees with the voltage listed on this name rating plate before connecting the centrifuge. Always mention the serial number and model or system ID number when contacting Beckman Coulter regarding your Optima L-XP ultracentrifuge.

## Controls and Indicators

---

### Power

A circuit breaker, labeled **I** (on) and **O** (off), is located on the right side panel of the Optima L-XP and controls the electrical power to the instrument. Power should be left on, except in the case of an emergency or when maintenance is required.

A red **POWER OFF** button is located on the base of the control head for emergency shut-down (see [Figure 1.1](#)). Pressing the **POWER OFF** button trips the circuit breaker to the off position. To return power to the instrument, the circuit breaker must be returned to the up position.

**Figure 1.1** Optima L-XP Control Head

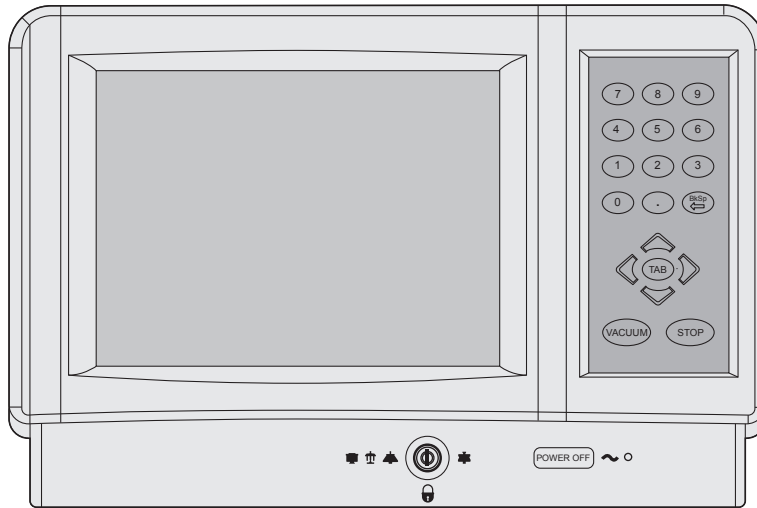

## Key Switch Positions

A key interlock switch is used to select normal, locked, or zonal operation (see [Figure 1.2](#)). Use the normal position for routine closed-door centrifugation, the locked position to prevent settings being changed during the run, and the zonal position for runs in which a zonal rotor is loaded and unloaded while spinning.

**Figure 1.2** Key Switch Positions

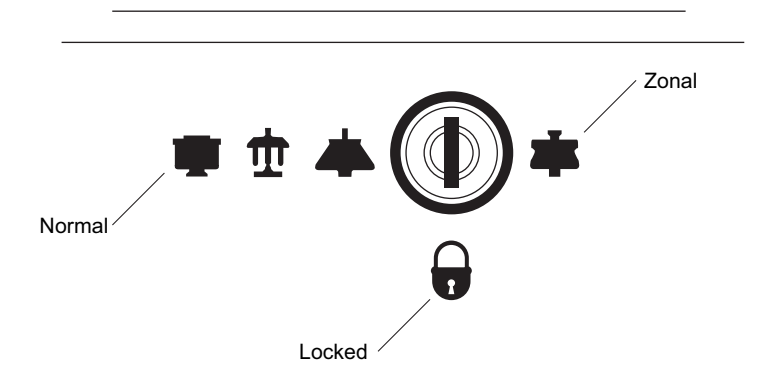

## Control Panel

The control panel ([Figure 1.3](#)) contains a display screen and keypad. Run information can be entered and advanced features accessed by using the drop-down menus on the touchscreen, the keypad, or a combination of both. You can use a finger, a stylus, or an implement such as a pencil eraser or point to access the touchscreen.

Figure 1.3 Control Panel

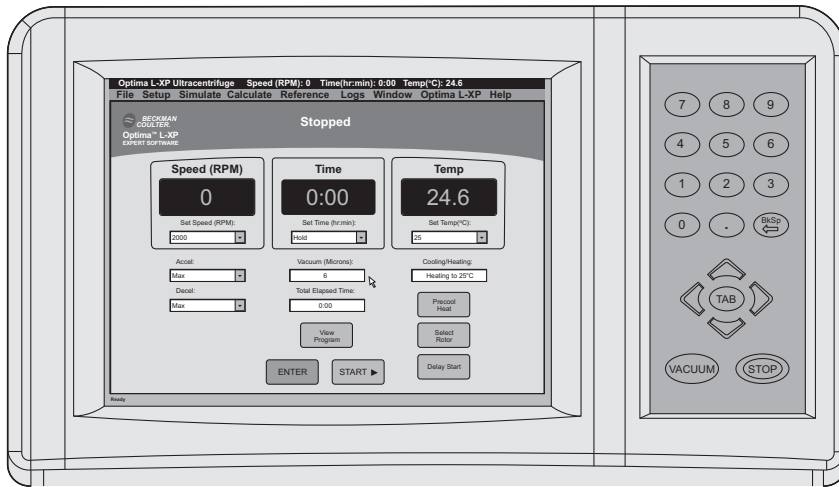

## Settings Screen

The main window is a touchscreen interface display, which comprises touch-sensitive display fields and buttons for entering and displaying run parameters and program information. Use your fingertip to press the buttons on the touchscreen or to access menus.

For manual operation, the Settings screen (see Figure 1.4) is used to enter the speed-time-temperature combination required for the run. In addition, you may select acceleration and deceleration profiles, preset the starting or ending time of the run, and precool or heat the instrument to the required temperature.

Figure 1.4 Settings Screen





When parameters are entered, the run is started by pressing **(Enter)**, then **(Start)**. (For safety reasons, the instrument does not start a run unless **(Start)** is activated within 5 seconds of activating **(Enter)**.) Pressing **(Stop)** (on the keypad) at any time terminates a run.

If the run was downloaded from a previously established program, the program name and the rotor in use is displayed.

### Step Run Program

The program window (see [Figure 1.5](#)) is accessed by selecting **Step Program Run** from the Setup menu. It contains the same information as the single-step window, except either single or multiple steps (up to five steps per program) can be entered before the run is started. The information is entered for each step, except Accel and Decel—acceleration profile will be for the first step only, and deceleration profile will be for the last step of the run.

**Figure 1.5** Step Program Screen

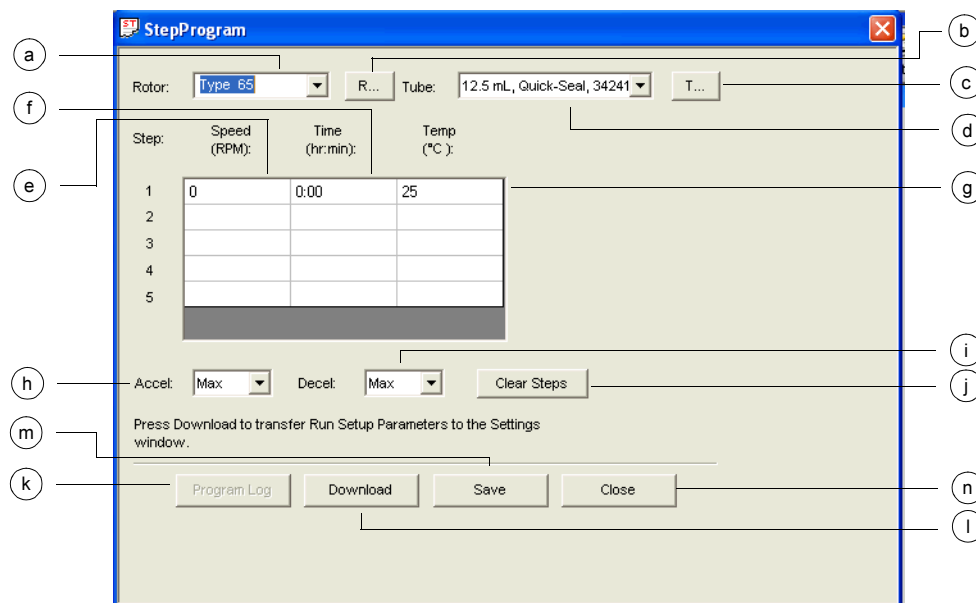

**Table 1.1** Step Program Screen Features

	Screen Element	Description
a	Rotor Menu	Rotor in use is entered or selected from the pull-down menu
b	Rotor List	Displays a full list of Beckman Coulter rotors
c	Tube List	Displays a list of tubes available for the selected rotor
d	Tube Menu	Tube in use is entered (optional)
e	Rotor Speed	Required rotor speed is entered for each step
f	Run Time	Required run time for each step is entered for a timed run
g	Run Temperature	Required run temperature is entered for each step

**Table 1.1** Step Program Screen Features

	Screen Element	Description
<b>h</b>	Acceleration	<i>First step only</i> —Maximum acceleration or one of nine slower acceleration profiles can be entered to minimize sample-to-gradient interface disturbance; Max (maximum) is the default
<b>i</b>	Deceleration	<i>Last step only</i> —Maximum deceleration, one of nine slower deceleration profiles, or No Brake can be entered to minimize sample-to-gradient interface disturbance; Max (maximum) is the default
<b>j</b>	(Clear Steps)	Pressed to erase information entered in all steps
<b>k</b>	(Program Log)	Pressed to access the last Program Log
<b>l</b>	(Download)	Pressed to download the program to the Settings window
<b>m</b>	(Save)	Pressed to save the program to the instrument memory
<b>n</b>	(Close)	Pressed to close the program without downloading it to the Settings window

Speed, time, and temperature values are entered for all steps, then acceleration and deceleration numbers for the complete run can be entered.

When run parameters for all steps are entered and downloaded to the Settings window, the run can be started by pressing (Enter), then (Start). (For safety reasons, the instrument will not start a run unless (Start) is activated within 5 seconds of activating (Enter).) A run can be terminated at any time by pressing (Stop) on the keypad.

### Advanced Use Window

Advanced functions that use centrifugation-related parameters, such as RCF,  $w^2t$ , separation type (pelleting or rate zonal), or specific sample or gradient, are used by accessing appropriate windows. These windows are described in [CHAPTER 2, Operation](#) or [CHAPTER 3, Simulations](#).

## Specifications

**NOTE** Only values with tolerances or limits are guaranteed data. Values without tolerances are informative data, without guarantee.

Specification	Description
<i>Speed</i>	<ul style="list-style-type: none"> <li>• Optima L-100 XP set speed:               <ul style="list-style-type: none"> <li>— 1000 to 100,000 RPM in 100-RPM increments</li> </ul> </li> <li>• Optima L-80 XP set speed:               <ul style="list-style-type: none"> <li>— 1000 to 80,000 RPM in 100-RPM increments</li> </ul> </li> <li>• Speed control:               <ul style="list-style-type: none"> <li>— Actual rotor speed, <math>\pm 10</math> RPM of set speed after equilibration (above 1000 RPM)</li> </ul> </li> <li>• Speed display:               <ul style="list-style-type: none"> <li>— Actual rotor speed in 10-RPM increments below 1000 RPM and 100-RPM increments <math>\geq 1000</math> RPM</li> </ul> </li> </ul>
<i>Time</i>	<ul style="list-style-type: none"> <li>• Set time:               <ul style="list-style-type: none"> <li>— To 999 hours 59 minutes; Hold for continuous runs</li> </ul> </li> <li>• Time display, manual operation:               <ul style="list-style-type: none"> <li>— Indicates time remaining in timed runs, time elapsed in Hold runs, or estimated time remaining in <math>w^2t</math> runs</li> </ul> </li> <li>• Time display, programmed operation:               <ul style="list-style-type: none"> <li>— Time remaining in step</li> </ul> </li> </ul>
<i><math>w^2t</math> Integrator</i>	<ul style="list-style-type: none"> <li>• Calculate time for <math>\omega^2t</math> <ul style="list-style-type: none"> <li>— Up to <math>9.99 \times 10^{14}</math> radians squared per second</li> </ul> </li> <li>• <math>\omega^2t</math> display:               <ul style="list-style-type: none"> <li>— Shows the accumulated <math>\omega^2t</math> to two significant digits (in exponential notation)</li> </ul> </li> </ul>
<i>Temperature</i>	<ul style="list-style-type: none"> <li>• Set temperature:               <ul style="list-style-type: none"> <li>— 0 to 40°C in 1°C increments</li> </ul> </li> <li>• Temperature control (after equilibration):               <ul style="list-style-type: none"> <li>— <math>\pm 0.3^\circ\text{C}</math> of set temperature</li> </ul> </li> <li>• Temperature display:               <ul style="list-style-type: none"> <li>— Actual rotor temperature in 0.1°C increments</li> </ul> </li> <li>• Ambient temperature range:               <ul style="list-style-type: none"> <li>— 10 to 40°C</li> </ul> </li> </ul>
<i>Humidity Restrictions</i>	<95% (noncondensing)
<i>Vacuum</i>	Below 5 microns (0.7 Pa)
<i>Acceleration</i>	10 acceleration profiles—9 slow rates or maximum acceleration from 0 to set speed

Specification	Description
<i>Deceleration</i>	11 deceleration profiles—9 slow rates, coasting to a stop without brake, or full dynamic braking from set speed
<i>Dimensions</i>	<ul style="list-style-type: none"> <li>• <i>Width</i>: 94.0 cm (37 in.)</li> <li>• <i>Depth</i>: 67.3 cm (26.5 in.)</li> <li>• <i>Height</i>: 125.7 cm (49.5 in.)</li> </ul>
<i>Weight</i>	465 kg (1025 lb)
<i>Ventilation Clearances</i>	<ul style="list-style-type: none"> <li>• <i>Sides</i>: 5.1 cm (2.0 in.)</li> <li>• <i>Rear</i>: 15.2 cm (6.0 in.)</li> </ul>
<i>Finishes</i>	<ul style="list-style-type: none"> <li>• <i>Keypad</i>: Coated polycarbonate</li> <li>• <i>Top surface</i>: Acrylic baking enamel</li> <li>• <i>Other surfaces</i>: General-purpose paint</li> </ul>
<i>Electrical Requirements</i>	<ul style="list-style-type: none"> <li>• <i>200/240-V instrument</i>: 180–264 VAC, 30 A, 50/60 Hz</li> <li>• <i>200/240-V instrument</i>: 198–264 VAC, 30 A, 50 Hz</li> </ul>
<i>Electrical Supply</i>	Class I
<i>Maximum Heat Dissipation into Room Under Steady-State Conditions</i>	3400 Btu/hr (1.0 kW)
<i>Noise Level 0.91 m (3 ft) in front of Ultracentrifuge</i>	<53 dBa
<i>Installation (Overvoltage) Category</i>	II
<i>Pollution Degree</i>	2 <sup>a</sup>

a. Normally only nonconductive pollution occurs; occasionally, however, a temporary conductivity caused by condensation must be expected.

## Available Rotors

All currently manufactured Beckman Coulter ultracentrifuge rotors can be used in the Optima L-XP series ultracentrifuges. The rotors are described in individual manuals that accompany each rotor. Information on rotors and accessories is also available in *Rotors and Tubes for Preparative Ultracentrifuges* (LR-IM) and in the Beckman Coulter *Ultracentrifuge Rotors, Tubes & Accessories* catalog (publication BR-8101). The Beckman Coulter web site, <http://www.beckmancoulter.com>, contains additional information about centrifugation processes and products.

## Introduction

---

*This chapter contains manual and programmed operating procedures. Refer to the applicable rotor manual for information about the use and care of rotors and accessories.*

## Power

---

If the power is off, flip the circuit breaker at the right side of the instrument to on (up position). Power should be left on except in the case of an emergency or when maintenance is required.

To end a run for any reason, press **(Stop)** on the keypad.

## Key Switch Positions

---

Insert the key into the interlock switch on the control head to select normal, locked, or zonal operation (see [Figure 2.1](#)). The arrow on the key should point in the direction of the selected position. Icons for normal, locked, and zonal are displayed next to the interlock on the control head.

**Figure 2.1** Key Switch Positions

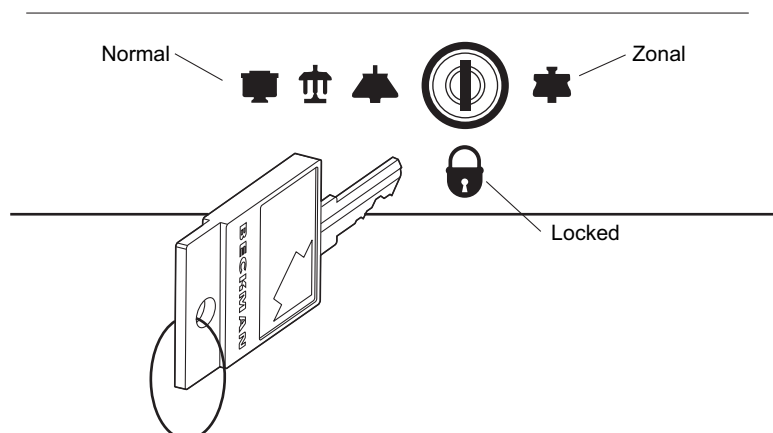

## Normal Position

Turn the key to the normal position for routine closed-door centrifugation. The key should be removed while in this position.

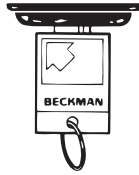

Normal Key Switch Position

## Locked Position

To ensure that run parameters are not changed during centrifugation, turn the key to the vertical position to run the instrument in locked operation. The key should be removed while in this position. LOCKED mode will appear at the bottom of the Status window.

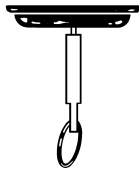

Locked Key Switch Position

## Zonal Position

Turn the key to the zonal position for runs in which a zonal rotor is being used. The key should not be removed while the instrument is running in a zonal operation. ZONAL mode will appear at the bottom of the Status window.

As a safety feature, to repeat a zonal run you must reset the key by turning it clockwise out of the zonal position and then back again into the zonal position. Then press **(Enter)** and **(Start)** again to begin the next zonal run.

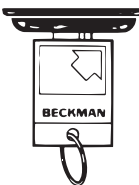

Zonal Key Switch Position

## Touchscreen Interface

---

The operation of the Optima L-XP is controlled through the touchscreen interface display, which comprises touch-sensitive display fields and buttons for entering and displaying run parameters

and program information. Use your fingertip to press the buttons on the touchscreen or to access menus.

During operation, the Speed, Time, and Temp display windows on the Settings screen display real-time status.

## Basic Operation

Load and install the rotor as described in the applicable rotor manual, then close the door.

Run information is entered directly and advanced features accessed by using the drop-down menus on the Settings screen, the keypad, or a combination of both as shown in [Figure 2.2](#).

**Figure 2.2** Touchscreen and Keypad Operation

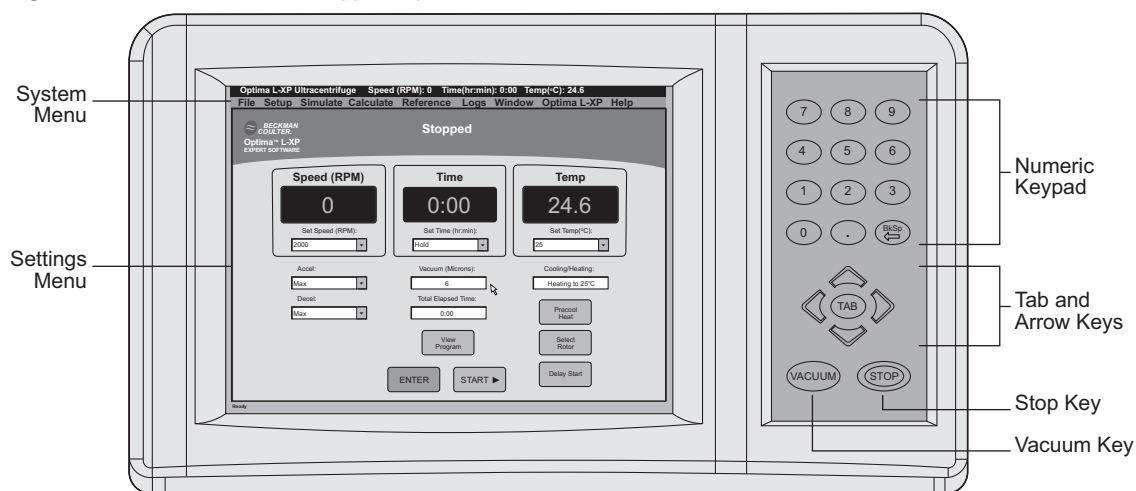

**Touchscreen**—Enter run information using the touchscreen by touching the arrow to the right of a parameter field, then scrolling to the required value on the drop-down menu. **Save**, **Enter**, and **Start** (not accessible through the keypad) are initiated by simply touching the key. The System menu, which can only be accessed using the touchscreen, includes:

- **File**—Contains the print menus and lists previously opened files
- **Setup**—Step Program Run, RCF Run,  $\omega^2t$  Run, Substitute Rotor Run, Auto Pelleting Run, Auto Rate Zonal Run, and Recall Program menu
- **Simulate**—ESP Pelleting Run, ESP Rate Zonal Run, ESP Plasmid Run, ESP RNA Run (Best), ESP RNA Run (Fast) simulations, as well as Recall Simulation
- **Calculate**—Pelleting Time, Concentration Measures, Refractive Index/Density, Reduced Speed for Dense Solutions, Reduced Speed for Precipitating Solutions, Sedimentation Coefficient from Run Data, Sedimentation Coefficient from Molecular Mass
- **Reference**—Rotor Catalog, Tube Catalog, and Chemical Resistance Chart
- **Logs**—Instrument Usage Log, Display Last Run Record, and Print Last Run Record Automatically selection
- **Window**—Restore Windows and Display Total  $\omega^2t$  Box functions

- **Optima L-XP**—Field Service and System Management access, Change PIN and Export Data functions, and About Optima L-XP which contains software version number, copyright information, and local field service name and contact information

*Keypad*—Information (except system menus and the **Save** , **Enter** , and **Start** functions) is entered using the keypad by using the tab and arrow keys to navigate through the Setup windows and entering values using the numeric keypad. (The backspace key on the keypad moves the cursor to the left, erasing characters.) The **Vacuum** key, used to start the vacuum system before the run begins, and the **Stop** key, used to stop a run for any reason, are accessible only through the keypad, and are available regardless of the window displayed.

Use one of the setup procedures described in the following pages to set up and start the run. When the run begins, the following actions occur:

- The vacuum system is activated (unless the vacuum was previously started) to reduce chamber pressure to below 5 microns (0.7 Pa). The chamber pressure is displayed in microns in the Status window.
- When the rotor speed reaches 1000 RPM, the set speed is checked against the overspeed disk. If set speed is greater than the maximum speed allowed by the disk, the speed setting is lowered to the disk maximum speed. An error message alerts you to the change.
- The rotor will not accelerate beyond 3000 RPM until the chamber pressure drops below 750 microns. At that time the rotor accelerates to the set speed.
- The run status is continuously displayed in the Status window.

## Logging In

---

Depending on the type of action to be performed, you may need to log in prior to the start of a run. If User Login is enabled by your Administrator, you will be required to enter your user name accompanied by a Personal Identification Number (PIN). Check with your Administrator to obtain a user profile.



Login Button

### To log in:

---

- 1 To log in prior to performing any other actions, press the **Login** button on the Settings screen. The User Login screen appears (see [Figure 2.3](#)). Go to Step 2 if you pressed the **Start** button to start a run and the User Login screen automatically displayed.

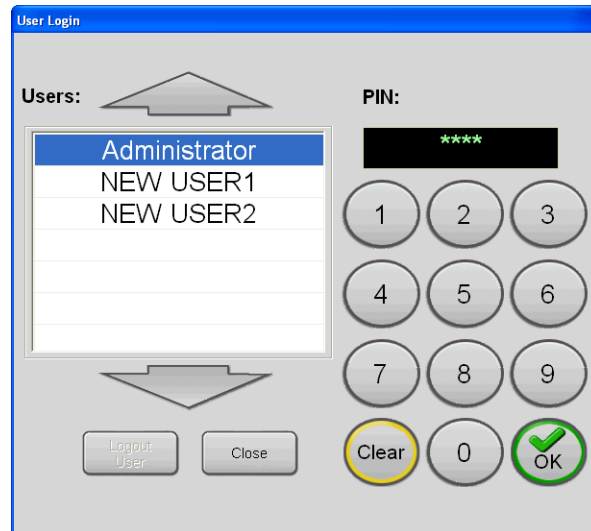

**Figure 2.3** User Login Screen

- 2 Select your user name, enter your PIN on the keypad, and press **OK** to accept. The Settings screen returns to view. If you were required to log in, the run starts or, if enabled by the administrator, the Run Comment screen appears.

**NOTE** If the instrument is powered down while the user is logged in, the user will automatically be logged in when power is restored to the instrument. To prevent automatic login upon machine startup, please log off and allow at least 5 seconds for processing before turning off the instrument.

## System-Level Operations

The Administrator performs system-level operations, such as adding and deleting users, requiring User Login, requiring Rotor Selection, and enabling a Run Comment before starting a run. These operations are accessed through the System Management screen. Any user with Administrator privileges has access to these functions.

### To log in as the Administrator:

- 1 Log in as the Administrator (if you are not logged in already).
- 2 On the Settings screen, select **System Management** from the Optima L-XP drop-down menu. The System Management screen appears as shown in [Figure 2.4](#).

**Figure 2.4** System Management Screen

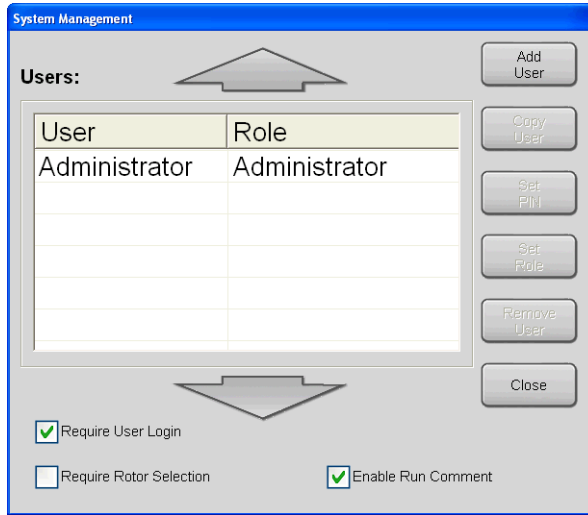

## Adding a User

To add a user:

- 1 From the System Management screen, press the **Add User** button. The Add User Name screen appears as shown in [Figure 2.5](#).

**Figure 2.5** Add User Screen

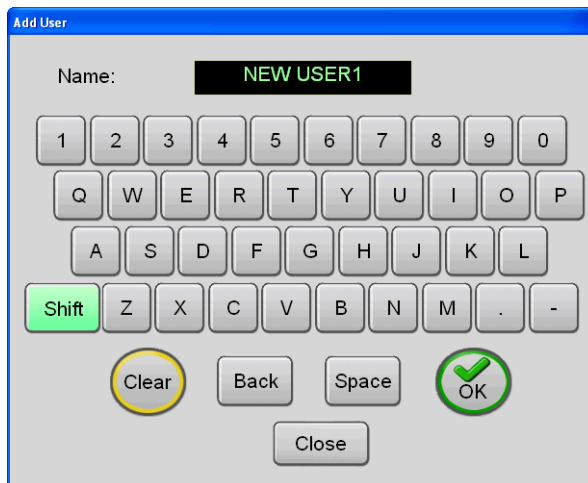

- 2 Enter a user name on the keypad. Uppercase letters are default. To enter lowercase letters, press the **Shift** key. Press **Back** to erase entered characters one at a time. To clear the entire entry, press **Clear**.

- When the user name is entered, press the **OK** button. The New PIN screen appears as shown in [Figure 2.6](#).

**Figure 2.6** New PIN Screen

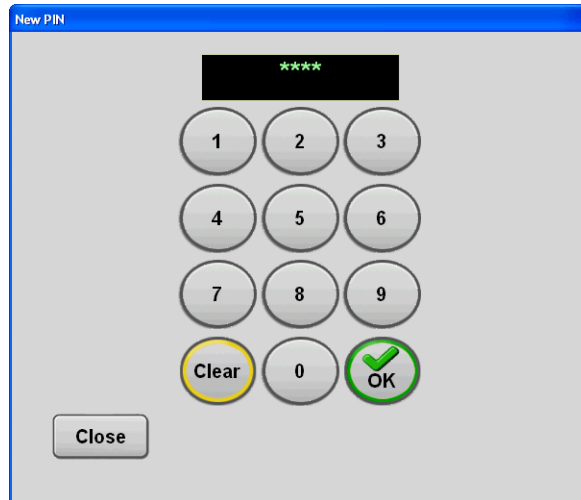

- Enter a PIN number 4 to 6 digits in length on the keypad, and press the **OK** button to accept. The Confirm PIN screen appears as shown in [Figure 2.7](#).

**NOTE** The PIN number is masked on the screen during entry.

**Figure 2.7** Confirm PIN Screen

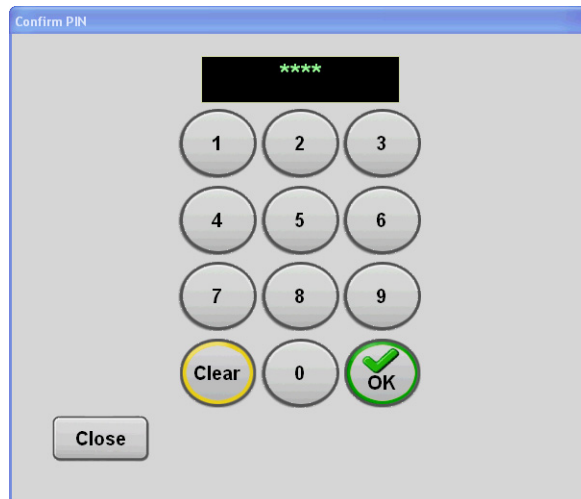

- 5 Enter the PIN number again, and press the **(OK)** button to accept. The Set Role screen appears as shown in [Figure 2.8](#). On this screen, Administrators must assign one of three security roles that control access to specific instrument functions:
  - **Administrator** — This level can access all instrument functions including adding users and instrument settings.
  - **Super User** — This level can create and run programs, use simulations and calculations, modify the rotor library, and access instrument logs.
  - **Operator** — This level can access selected runs and programs.

**Figure 2.8** Set Role Screen

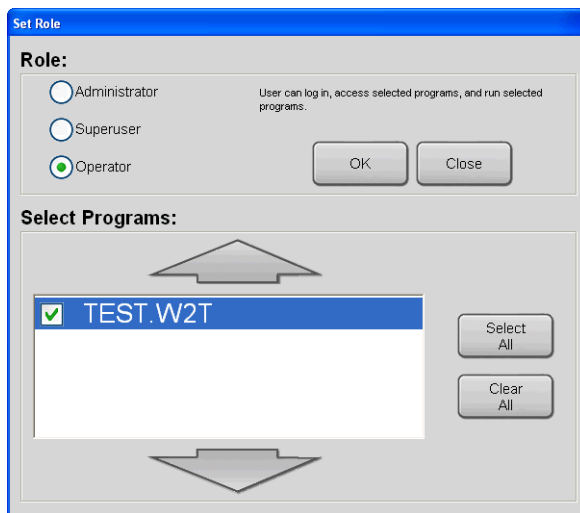

**NOTE** Although not listed on the Set Role screen, there is an additional security role for Field Service. This role has the same access as an Administrator but with additional field service access.

- 6 Assign the user a security level by selecting the appropriate role.
- 7 If programs have been added to the Program Library, you can assign the new user access to these programs by selecting each in the Selecting Programs menu of the Set Role screen. Select a single program by pressing on the program name or, press the **(Select All)** or **(Clear All)** button as appropriate.
- 8 Press the **(OK)** button to confirm. To add another user, repeat Steps 2 to 8.

## Copying Users

The profiles of existing users may be copied to create a new user profile that retains the same security role as the original.

**To copy a user:**

- 1 From the System Management screen, select a user name from the user list and press the **(Copy User)** button. The Copy User Name screen appears.
- 2 Enter a user name on the keypad. Uppercase letters are default. To enter lowercase letters, press the **(Shift)** key. Press **(Back)** to erase entered characters one at a time. To clear the entire entry, press **(Clear)**.
- 3 When the user name is entered, press the **(OK)** button. The New PIN screen appears.
- 4 Enter a PIN number 4 to 6 digits in length on the keypad, and press the **(OK)** button to accept. The Confirm PIN screen appears.  
**NOTE** The PIN number is masked on the screen during entry.
- 5 Enter the PIN number again, and press the **(OK)** button to accept. The System Management screen returns to view, and the user name is added from the list.

**Set PIN Number**

The PIN numbers of existing users may be changed in scenarios where the original PIN has been forgotten or the security of the original PIN number has been compromised.

**To set a PIN number:**

- 1 From the System Management screen, select a user name from the user list and press the **(Set PIN)** button. The New PIN screen appears.
- 2 Enter a new PIN number 4 to 6 digits in length on the keypad, and press the **(OK)** button to accept. The Confirm PIN screen appears.  
**NOTE** The PIN number is masked on the screen during entry.
- 3 Enter the PIN number again, and press the **(OK)** button to accept. The System Management screen returns to view.

## Set Role

The security level assigned to existing users may be changed if access to specific instrument functions and programs needs to be expanded or restricted.

### To assign a role to a user:

---

- 1 From the System Management screen, select a user name from the user list and press the **(Set Role)** button. The Set Role screen appears. On this screen, reassign one of three security roles that control access to specific instrument functions.
    - **Administrator** — This level can access all instrument functions including adding users and instrument settings.
    - **Super User** — This level can create and run programs, use simulations and calculations, modify the rotor library, and access instrument logs.
    - **Operator**— This level can access selected runs and programs.
  - 2 Reassign the user a security level by selecting the appropriate option.
  - 3 If programs have been added to the Program Library, you can assign the user access to these programs by selecting each in the Selecting Programs menu of the Set Role screen. Select a single program by pressing on the program name or, press the **(Select All)** or **(Clear All)** button as appropriate.
  - 4 Press the **(OK)** button to confirm. The System Management screen returns to view.
- 

## Removing Users

### To remove a user:

---

- 1 From the System Management screen, select a user name from the user list and press the **(Remove User)** button. A message appears to confirm the action.
- 2 Press the **(Yes)** button to confirm. The System Management screen returns to view, and the user name is deleted from the list.

**NOTE** The default Administrator role cannot be removed from the user list.

---

## Require User Login

A user may be required to log in prior to starting a run. With each login, the user actions are recorded in the run log.

### To set up required user login:

- 1 From the System Management screen, check the box next to Require User Login (see [Figure 2.9](#)) to enable this function.

**Figure 2.9** Enable User Login Option

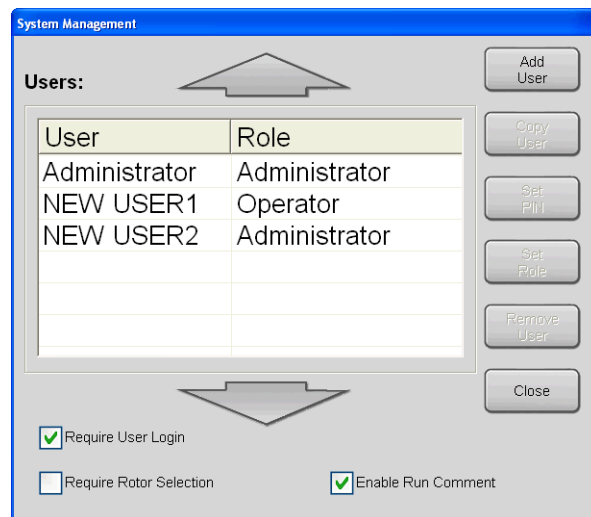

- 2 Press the **Close** button to exit the System Management screen.

## Required Rotor Selection

When Require Rotor Selection is enabled, the user must select a rotor before starting a run. If a rotor is not selected, the user will be prompted to select the rotor in use.

### To select a rotor:

- 1 From the System Management screen, check the box next to Require Rotor Selection to enable this function.
- 2 Press the **Close** button to exit the System Management screen.

## Enable Run Comment

When a Run Comment is enabled, the user can enter a run comment (up to 255 characters) before starting a run. A run comment is typically used to record the batch and lot information.

### To enable run comment:

- 1 From the System Management screen, check the box next to Enable Run Comment to enable this function.
- 2 Press the **Close** button to exit the System Management screen.

## Manual Operation

You can set up a run manually using the Settings Screen as shown in [Figure 2.10](#), or by using a previously saved run program or a simulation program. The following procedure describes setting up a run using manual setup.

**Figure 2.10** Settings Screen





**To set up a run manually:**

---

- 1 Enter required speed (between 1000 RPM and the rotor maximum speed) by keying in the numbers or selecting a speed from the Set Speed (RPM) drop-down menu.

---

- 2 Enter required time (up to 999 hours and 59 minutes) by keying in the hours and minutes or selecting a time (or Hold) from the Time (hr:min) drop-down menu.

---

- 3 Enter temperature (between 0 and 40°C) by keying in the numbers or selecting a value from the Set Temp (°C) drop-down menu.

**NOTE** If Run Comment has been enabled by the Administrator, the user is prompted to enter a comment (up to 255 characters) before starting the run. This feature is typically used to record the batch and lot information.

To start the run at this point, using default settings for the remaining parameters, press **Enter**, then **Start**. The default maximum acceleration and deceleration times will be used; to select acceleration and deceleration profiles, go on to Steps 4 and 5.

**NOTE** If you press **Start** without first pressing **Enter**, the run will not start. You must press **Enter** then **Start** (within 5 seconds) to begin a run.

---

- 4 To minimize sample-to-gradient interface disturbance, enter one of nine slower acceleration profiles (see [Table 2.1](#)) by keying in the profile number or making a selection from the Accel drop-down menu.

---

- 5 To minimize sample-to-gradient interface disturbance, enter one of nine slower deceleration profiles (see [Table 2.1](#)), or No Brake, by keying in the profile number or making a selection from the Decel drop-down menu.

**NOTE** You can start the run at this point, or enter additional (optional) parameters, such as precooling or heating the chamber or setting the run for a delayed start (delay time must be less than one week).

**Table 2.1** Acceleration and Deceleration Profiles

Acceleration			Deceleration		
Profile Number	Transition <sup>a</sup>		Profile Number	Transition <sup>b</sup>	
	Speed (RPM)	Time		Speed (RPM)	Time
Max	Maximum Acceleration		Max	Maximum Deceleration	
1	170	2:00	1	170	2:00
2	350	2:40	2	350	2:40
3	500	3:00	3	500	3:00
4	170	3:00	4	170	3:00
5	350	4:00	5	350	4:00
6	500	4:30	6	500	4:30
7	170	4:00	7	170	4:00
8	350	5:20	8	350	5:20
9	500	6:00	9	500	6:00
			No Brake	Rotor coasts from full speed to stop	

- a. The speed at which the rotor ends its slow acceleration and begins maximum acceleration to set speed.
- b. The speed at which the rotor begins its slow deceleration; until that point the rotor has been decelerating with full dynamic braking.

- 6 Press **(Delay Start)**, then enter the time that you want the run to begin or end (see [Figure 2.11](#)). Press **(OK)**. The run begins when the Delay Start countdown has ended.

**Figure 2.11** Delay Start Screen

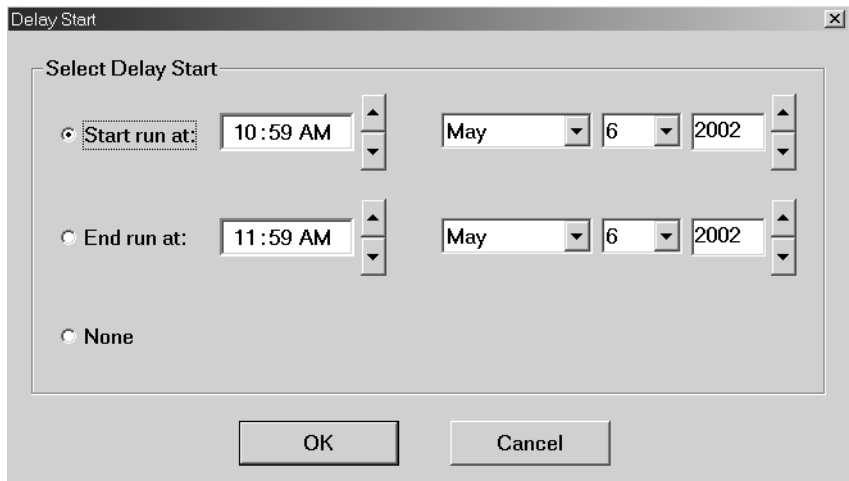

**NOTE** When the Delay Start function is used in conjunction with the Require User Login function, users are automatically logged out after two minutes of inactivity.

7 To cancel Delay Start, press the **(Stop)** button on the control panel.

8 Press **(Precool/Heat)**, then enter chamber precool or preheat temperature (see [Figure 2.12](#)). Press **(Start Temp)** to begin temperature control.

**Figure 2.12** Precool/Heat Temperature Screen

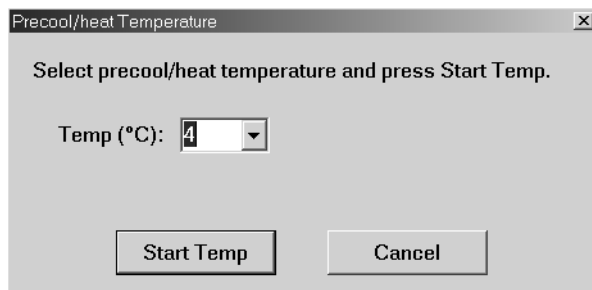

**NOTE** To save the run parameters for future recall, press **(Save)**, then enter a program name in the dialog box.

9 When all required parameters are entered, press **(Enter)**, then **(Start)**. You can terminate a run at any time by pressing **(Stop)** on the keypad.

**NOTE** Run parameters may be printed out for record keeping purposes. See [APPENDIX A, Preinstallation Requirements](#), for printer hookup instructions.

If you downloaded the run from a previously established program, the program name and the rotor in use (if a rotor was selected) will be displayed below the parameter entry positions.

## Programmed Operation

Program options are accessed through the Setup menu as shown in [Figure 2.13](#). You can enter, save, and recall programs containing protocols that you plan to re-use. Each saved program is stored in a separate file for easy run duplication. Several of the program setup windows can also be used to determine parameters through calculations or conversions. Most program setup windows have an upper portion where calculations and conversions are done, and a lower portion where you can enter additional run parameters if you want to download or save the program.

**Figure 2.13** Setup Menu



If you downloaded a program before you saved it, and you are *still in the Settings window*, you can go back to that program window by pressing **View Program**. If you downloaded a program before you saved it, and you are *no longer in the Settings window*, you may be able to retrieve the program from the File menu (see [Figure 2.14](#)) in the top menu bar.

**Figure 2.14** File Types

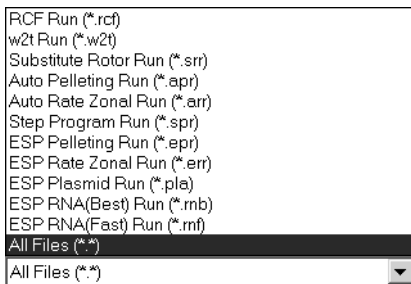

Step and ESP programs may be printed out for record keeping purposes. See [APPENDIX A, Preinstallation Requirements](#), for printer hookup instructions.

## Step Program

### To use step program:

- 1 Select **Step Program Run** from the Setup menu (see [Figure 2.15](#)).

**Figure 2.15** Step Program Screen

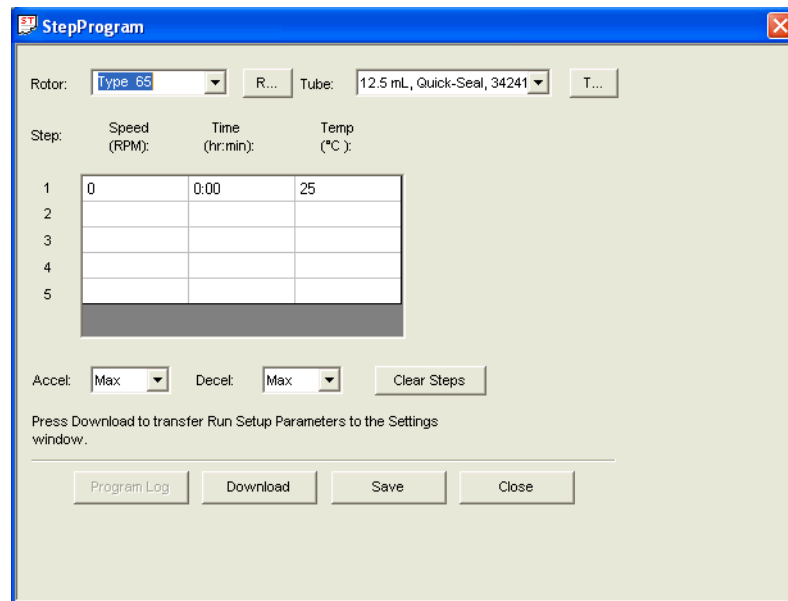

- 2 Enter rotor name and tube type (optional) or press **(R...)** (rotor) and select from the drop-down menu.

**NOTE** Continuous flow and zonal rotors are only used in single step runs; conversion functions do not apply to these rotors.

- 3 Enter speed, time, and temperature settings for all steps required (up to five steps per run).

**NOTE** Use the **(Clear Steps)** button to clear all entered steps to re-enter information.

After speed, time, and temperature values are entered for all steps, you can enter acceleration (*first step only*) and deceleration (*last step only*) profile numbers (see [Table 2.1](#)) for the complete run.

- 4 Enter one of nine slower acceleration profiles by keying in the profile number or making a selection from the Accel drop-down menu.

- 5 Enter one of nine slower deceleration profiles, or No Brake, by keying in the profile number or making a selection from the Decel drop-down menu.

- 6 To save the program for later recall, press **(Save)**. The Save As dialog box opens, and you can use the on-screen keyboard (see [Figure 2.16](#)) to specify a filename.

**Figure 2.16** Save As Dialog

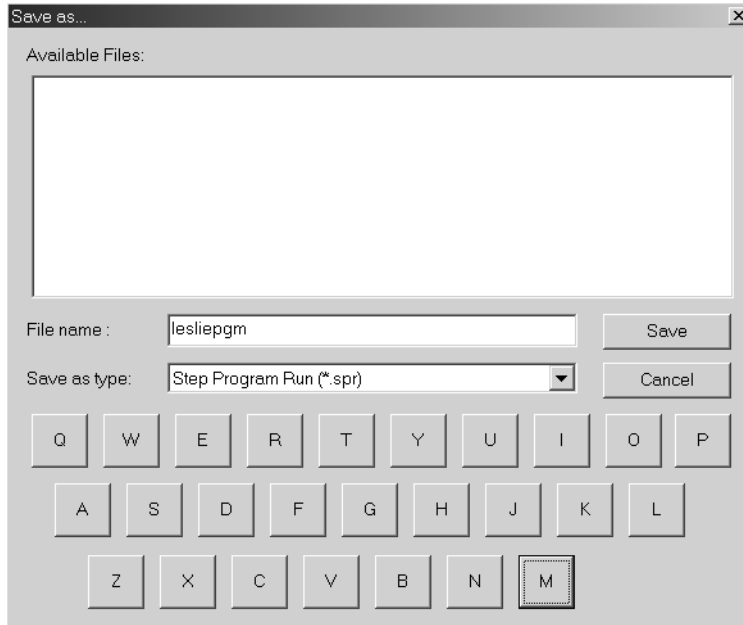

**NOTE** If you do not save the program under a new filename, it will be overwritten when a new step program is run.

- 7 Press **(Download)** to transfer the run parameters to the Settings window; if not saved to a specific filename, the program is automatically saved to a temporary file called LastStepProgram.spr. (Or press **(Close)** to close the program window without downloading it.)
- 8 Press **(Precool Heat)** to enter chamber precool or preheat temperature. Select temperature, then press **(Start Temp)**. The vacuum will start automatically.  
or  
Press **(Vacuum)** on the keypad to start or stop the vacuum pump.  
When all required parameters are entered, press **(Enter)**, then **(Start)**. A run may be terminated at any time by pressing **(Stop)** on the keypad.

## RPM to RCF Toggle

### To toggle between RPM and RCF:

1 On the Settings screen, press the **Display RCF** button to toggle between RPM and RCF (relative centrifugal field) modes. RPM indicates rotor speed in revolutions per minute while RCF represents the ratio of the centrifugal acceleration at a specified radius and speed to the standard acceleration of gravity.

2 Press the **Display RPM** button to return to RPM mode.

**NOTE** A rotor must be selected before toggling from RPM to RCF. The ultracentrifuge requires the rmax of the rotor on which to perform calculations.

## RCF Conversion

This window allows you to enter RCF (relative centrifugal force) (see [Figure 2.17](#)) instead of RPM (revolutions per minute). The software then calculates the RPM necessary to achieve the required RCF.

**NOTE** This window can also be used to calculate RCF from a given RPM.

**Figure 2.17** RCF Run Screen

The screenshot shows a software window titled "RCF" with a blue title bar and a close button. The window content is as follows:

- Header: RCF <--> Speed
- Section: Conversion:
  - Rotor: SW 65 Ti (dropdown menu) R... (button)
  - Tube: 5.2 mL, Open Top, 326819 (dropdown menu) T... (button)
  - Radio buttons:  RCFmax <--> Speed and  RCFav <--> Speed
  - Fields: RCFmax (xg): 0 and Speed (RPM): 0 (dropdown menu)
- Section: Run Setup Parameters:
  - Speed (RPM): 0 (dropdown menu)
  - Time (hr:min): 0:00 (dropdown menu)
  - Temp (°C): 25 (dropdown menu)
  - Accel: Max (dropdown menu)
  - Decel: Max (dropdown menu)
- Text: Press Download to transfer Run Setup Parameters to the Settings window.
- Buttons: Program Log, Download, Save, Close

### To use RCF:

---

- 1 Select **RCF Run** from the Setup menu.
- 2 Enter rotor and tube in use or press **(R...)** (rotor) and select a rotor and tube combination from the rotor library.

**NOTE** Continuous flow and zonal rotors are only used in single step runs; no conversion functions apply to these rotors.

---

- 3 Select **RCFmax > Speed** (to use the tube's maximum radius) or **RCFav > Speed** (to use the tube's average radius).
- 

- 4 Enter the required RCF.

The equivalent RPM will be calculated and displayed. You can enter the additional run parameters then download the settings to the Settings window and start the run, or save as a program before downloading.

**NOTE** To save the program for future recall, press **(Save)**, then enter a program name in the dialog box. If the program is a modification of a previously saved program that you want to retain, you can save the new version under a different name by selecting **Save As** from the File menu.

---

- 5 Press **(Download)** to transfer the run parameters to the Settings window. If not saved to a specific filename, the program is automatically saved to a temporary file called LastRCF.rcf.
- 

- 6 Press **(Enter)**, then **(Start)** to run the program.
- 

## $w^2t$

This window (see [Figure 2.18](#)) allows you to set the run time so that the run will stop when a required  $w^2t$  (total accumulated centrifugal effect) is achieved.

**NOTE** The Total  $w^2t$  window appears by default on the Settings screen. Select **Display Total  $w^2t$**  from the Window drop-down menu to remove or restore this window on the Settings screen.

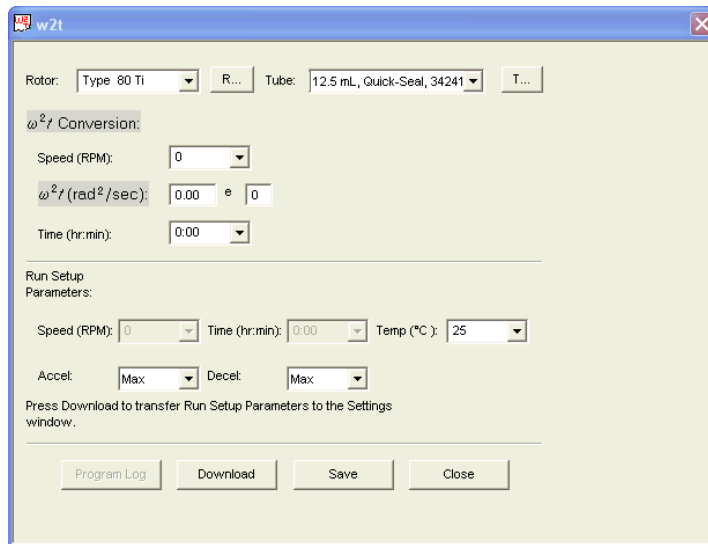

Figure 2.18  $\omega^2t$  Run Screen**To set the run to stop at  $\omega^2t$ :**

- 1 Select **w2t Run** from the Setup menu.
- 2 Enter rotor and tube in use or press **(R...)** (rotor) and select a rotor and tube combination from the rotor library.
- 3 Enter speed (in RPM) and one of the remaining two values:  $\omega^2t$  (in radians squared per second) or time (in hours and minutes).  
The third value will be displayed.
  - Time, if you entered values for speed and  $\omega^2t$
  - $\omega^2t$ , if you entered values for speed and timeYou can enter the additional run parameters then download the settings to the Settings window and start the run, or save as a program before downloading.  
**NOTE** To save the program for future recall, press **(Save)**, then enter a program name in the dialog box. If the program is a modification of a previously saved program that you want to retain, you can save the new version under a different name by selecting **Save As** from the File menu.
- 4 Press **(Download)** to transfer the run parameters to the Settings window (or press **(Close)** to close the window without downloading it).
- 5 Press **(Enter)**, then **(Start)** to run the program. If not saved to a specific filename, the program is automatically saved to a temporary file called Lastw2t.w2t.

## Rotor Conversion

Calculates time required to duplicate run conditions using a different rotor and tube combination.

### To enter a substitute rotor speed:

- 1 Select **Substitute Rotor Run** from the Setup menu.
- 2 In the First Rotor Information area (see [Figure 2.19](#)), enter the rotor and tube used in the original protocol. The minimum tube radius and maximum tube radius (in millimeters) from the axis of rotation will be displayed if the tube selected is in the Tube Catalog.

**Figure 2.19** Substitute Rotor Screen

The screenshot shows the 'SubstituteRotor' window with the following fields and values:

- First Rotor Information:**
  - Rotor: Type 80 Ti
  - Tube: 12.5 mL, Quick-Seal, 34241
  - r<sub>min</sub> (mm): 41.0
  - r<sub>max</sub> (mm): 84.0
  - Speed (RPM): 0
  - Time (hr:min): 0:00
- Substitute Rotor Information:**
  - Rotor: SW 65 Ti
  - Tube: 5.2 mL, Open Top, 326819
  - Speed (RPM): 0
  - Time to duplicate run using substitute rotor (hr:min):
- Run Setup Parameters:**
  - Speed (RPM): 0
  - Time (hr:min):
  - Temp (°C): 25
  - Accel: Max
  - Decel: Max

Buttons at the bottom: Program Log, Download, Calculate, Save, Close.

- 3 Enter the speed and time of the run to be duplicated (also in the First Rotor Information area).
- 4 In the Substitute Rotor Information area, enter the new rotor and tube combination.
- 5 Enter the substitute rotor speed.

---

6 Press **Calculate**.

The run time will be calculated and displayed. You can enter the additional run parameters then download the settings to the Settings window and start the run, or save as a program before downloading.

**NOTE** To save the program for future recall, press **Save**, then enter a program name in the dialog box. If the program is a modification of a previously saved program that you want to retain, you can save the new version under a different name by selecting **Save As** from the File menu.

---

7 Press **Download** to transfer the run parameters to the Settings window. If not saved to a specific filename, the program is automatically saved to a temporary file called LastSubstituteRotor.srr.

---

8 Press **Enter**, then **Start** to run the program.

---

## Auto Pelleting

Set up run parameters for pelleting a specific particle as follows.

### To set auto pelleting:

---

1 Select **Auto Pelleting Run** from the Setup menu.

---

2 Specify the sedimentation coefficient of the particle of interest by selecting the bar, then using the keypad arrow keys to slide the indicator along the bar until the correct  $s$  value appears in the field to the right of the slide bar (see [Figure 2.20](#)).

**NOTE** Sedimentation coefficient value reported is usually  $s_{20, w}$ , which means 20°C in water. If the run temperature is set to other than 20°C, the  $s$  value must be adjusted for the temperature difference.

---

3 Enter the rotor and tube combination and the speed.

The run time required to pellet the particle (in water) will be calculated and displayed. You can enter the additional run parameters then download the settings to the Settings window and start the run, or save as a program before downloading.

**NOTE** To save the program for future recall, press **Save**, then enter a program name in the dialog box. If the program is a modification of a previously saved program that you want to retain, you can save the new version under a different name by selecting **Save As** from the File menu.

Figure 2.20 Auto Pelleting Run Screen

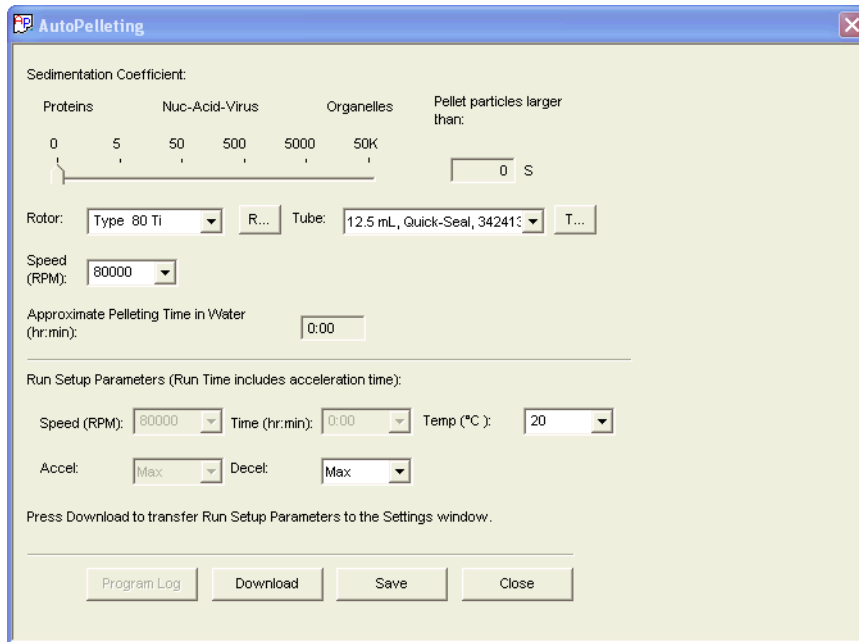

- 4 Press **(Download)** to transfer the run parameters to the Settings window. If not saved to a specific filename, the program is automatically saved to a temporary file called LastAutoPelleting.apr.
- 5 Press **(Enter)**, then **(Start)** to run the program.

## Auto Rate Zonal

Set up run parameters for rate zone separations as follows.

### To set auto rate zonal separations:

- 1 Select **Auto Rate Zonal Run** from the Setup menu.
- 2 Select the rotor and tube combination.
- 3 Select the Sedimentation Coefficient bar, then use the keypad arrow keys to slide the indicator along the bar to display the lower sedimentation coefficient particle of interest (see [Figure 2.21](#)). The software calculates a run time corresponding to a separation at 75% of the tube volume. It also calculates a hypothetical contaminant of minimum s value that separates this material at 25% of the tube volume.

Figure 2.21 Auto Rate Zonal Screen

The screenshot shows the 'AutoRateZonal' software interface. It includes a 'Sedimentation Coefficient' section with a scale from 0 to 50K, and a 'Resolve particles from' section with a scale from 25% to 75%. Below these are fields for Rotor (SW 65 Ti), Tube (5.2 mL, Open Top, 326819), Gradient (Sucrose 5-20% (w/w)), and Particle Density (1.3). A 'Computed Run Time' field shows 0:00. The 'Run Setup Parameters' section includes Speed (65000 RPM), Time (0:00), Temp (20°C), Accel (Max), and Decel (5). At the bottom are buttons for Program Log, Download, Save, and Close.

---

4 Select the gradient type.

---

5 Select particle density (in g/mL).

The run time required will be calculated and displayed. You can enter the additional run parameters then download the settings to the Settings window and start the run, or save as a program before downloading.

**NOTE** To save the program for future recall, press **(Save)**, then enter a program name in the dialog box. If the program is a modification of a previously saved program that you want to retain, you can save the new version under a different name by selecting **Save As** from the File menu.

---

6 Press **(Download)** to transfer the run parameters to the Settings window. If not saved to a specific filename, the program is automatically saved to a temporary file called AutoRateZonal.arr.

---

7 Press **(Enter)**, then **(Start)** to run the program.

---

## Recall Program

You can recall previously saved programs containing protocols that you want to re-use or modify.

### To recall a previously-saved program:

---

- 1 Select **Recall Program** from the Setup menu.
  - 2 Select the program you want to recall (see [Figure 2.22](#)).
- 

**Figure 2.22** Open File Dialog

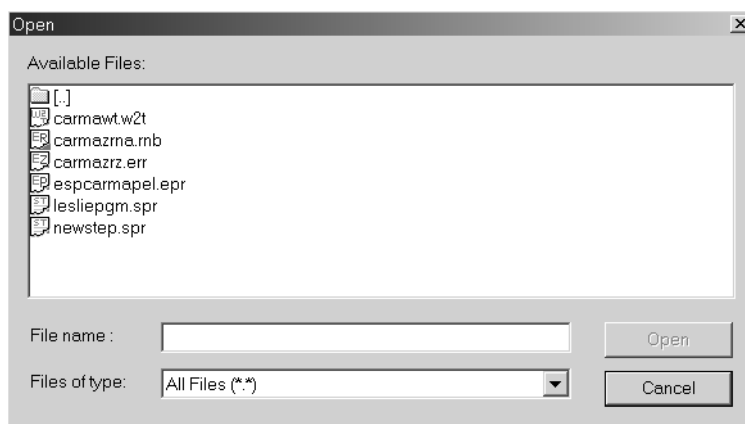

- 3 Press **(Open)** to open the program.
  - 4 Press **(Download)** to transfer the run parameters to the Settings window.
- 

**NOTE** You can modify the program before running it, but changes will not be saved unless you save the altered program under a new name.

---

- 5 Press **(Enter)**, then **(Start)** to run the program.
- 

## Remote Operation

---

The Optima L-XP ultracentrifuge may be operated from a remote computer. See [APPENDIX B, Remote Access](#), for more information on this feature.

## Using Calculation Features

The calculations feature performs a variety of calculations commonly used in ultracentrifugation. These calculations help simplify run preparation and are accessed from the Calculate menu (see [Figure 2.23](#)) during the setup process, but cannot be downloaded to a setup screen.

**Figure 2.23** Calculate Menu

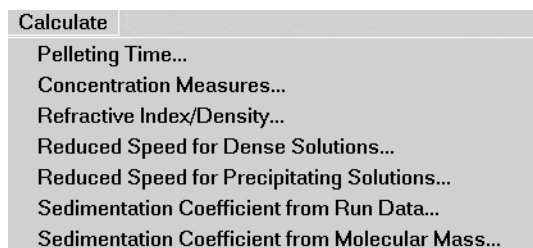

### Pelleting Time Calculation

To calculate the pelleting time:

- 1 Select **Pelleting Time** from the Calculate menu.
- 2 Select the rotor and tube in use.
- 3 Enter the sedimentation coefficient of the particles being separated (see [Figure 2.4](#)).

**Figure 2.24** Calculate Pelleting Time Screen

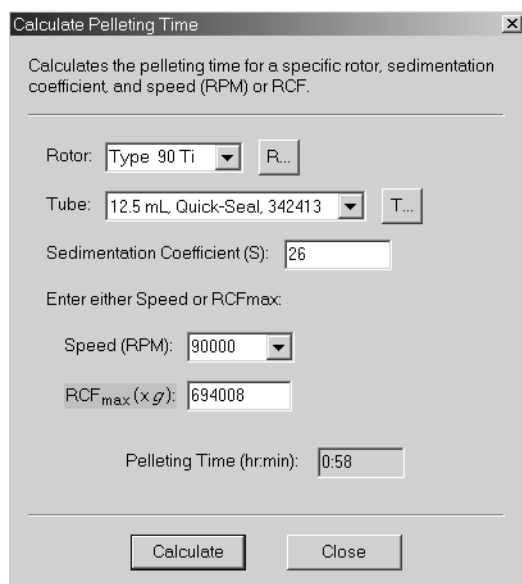

- 
- 4 Enter the speed in RPM or RCF.

---

  - 5 Press **Calculate**.  
The time required to pellet the particles appears in the Pelleting Time (hr:min) field, and the RCF will be displayed if you selected RPM, or RPM will be displayed if you selected RCF.

---

  - 6 Note the calculated time, then press **Close** to close the window.
- 

## Concentration Measures

To convert units of measurement:

- 
- 1 Select **Concentration Measures** from the Calculate menu.

---

  - 2 Select a gradient solution (sucrose or CsCl) as shown in [Figure 2.25](#).

**Figure 2.25** Calculate Concentration Measures Screen

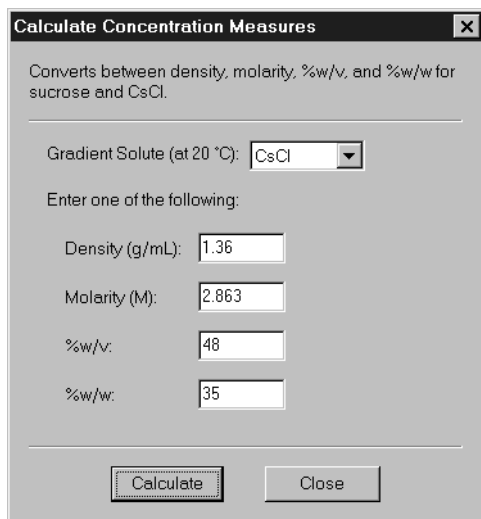

Calculate Concentration Measures

Converts between density, molarity, %w/v, and %w/w for sucrose and CsCl.

Gradient Solute (at 20 °C): CsCl

Enter one of the following:

Density (g/mL): 1.36

Molarity (M): 2.863

%w/v: 48

%w/w: 35

Calculate Close

- 
- 3 Enter the value for one of: density, molarity, %w/v (weight-to-volume), or %w/w (weight-to-weight).

---

  - 4 Press **Calculate**.  
The remaining three parameters are calculated and displayed.



- 
- 5 Note the calculated parameters, then press **Close** to close the window.
- 

## Refractive Index/Density

To calculate values of refractive index, density, or concentration:

- 
- 1 Select **Refractive Index/Density** from the Calculate menu.
- 
- 2 Enter the value for one of: refractive index, density, or molarity (see [Figure 2.26](#)).

**Figure 2.26** Calculate Refractive Index/Density Screen

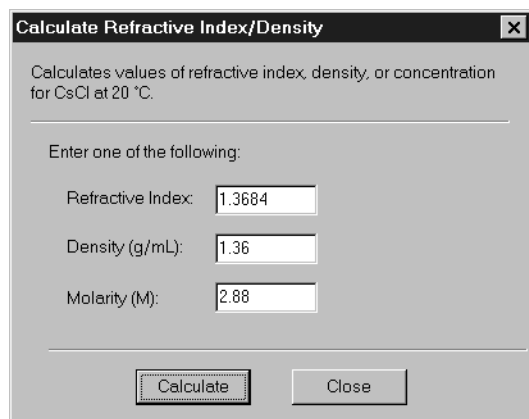

- 
- 3 Press **Calculate**.  
The remaining two parameters are calculated and displayed.
- 
- 4 Note the calculated parameters, then press **Close** to close the window.
- 

## Speed Reduction for Dense Solutions

Reduce run speed when centrifuging a solution with a density greater than the allowable density rating of the rotor (as listed in the applicable rotor manual) to protect the rotor from excessive stresses due to the added load.

**To calculate reduced speed for dense solutions:**

- 1 Select **Reduced Speed for Dense Solutions** from the Calculate menu.
- 2 Select a rotor and tube combination (see [Figure 2.27](#)). The maximum speed for that rotor and tube combination will be displayed.

**Figure 2.27** Calculate Reduced Rotor Speed for Dense Solutions Screen

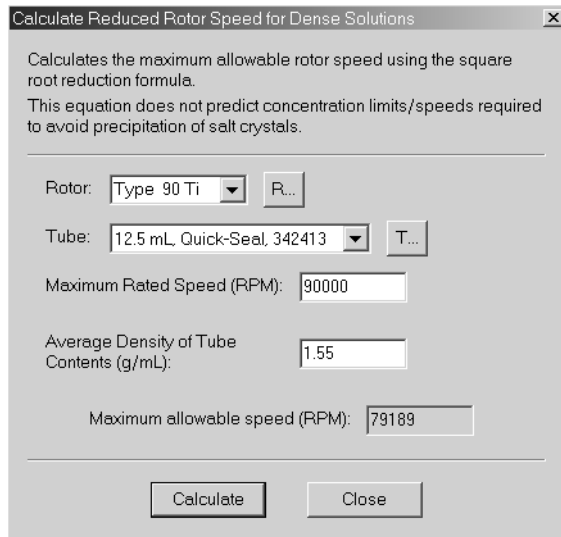

- 3 Enter the average density of the tube contents in g/mL.
- 4 Press **Calculate** .  
The maximum allowable speed is displayed.
- 5 Note the calculated speed, then press **Close** to close the window.

## Speed Reduction for Precipitating Solutions

Reduce run speed to avoid precipitation of CsCl during centrifugation of concentrated CsCl solutions.

**To calculate reduced speed for precipitating solutions:**

- 1 Select **Reduced Speed for Precipitating Solutions** from the Calculate menu.
- 2 Select a rotor and tube combination (see [Figure 2.8](#)).

**Figure 2.28** Calculate Reduced Rotor Speed for Precipitating Solutions Screen

Calculate Reduced Rotor Speed for Precipitating Solutions

Calculates the maximum allowable rotor speed for CsCl solutions.

Rotor: Type 90 Ti R...

Tube: 12.5 mL, Quick-Seal, 342413 T...

Average Density of Tube Contents (g/mL): 1.67

Maximum allowable speed (RPM): 43000

Calculate Close

- 3 Enter the average density of the tube contents in g/mL.
- 4 Press **Calculate**.  
The maximum allowable speed is displayed.
- 5 Note the calculated speed, then press **Close** to close the window.

**Sedimentation Coefficient from Run Data**

Calculate the sedimentation coefficient from the given run data.

### To calculate sedimentation coefficient:

- 1 Select **Sedimentation Coefficient from Run Data** from the Calculate menu.
- 2 Select a rotor and tube combination, location from meniscus, gradient, particle density speed, time, and run temperature from the drop-down menus (see [Figure 2.29](#)).

**Figure 2.29** Calculate Sedimentation Coefficient from Run Data Screen

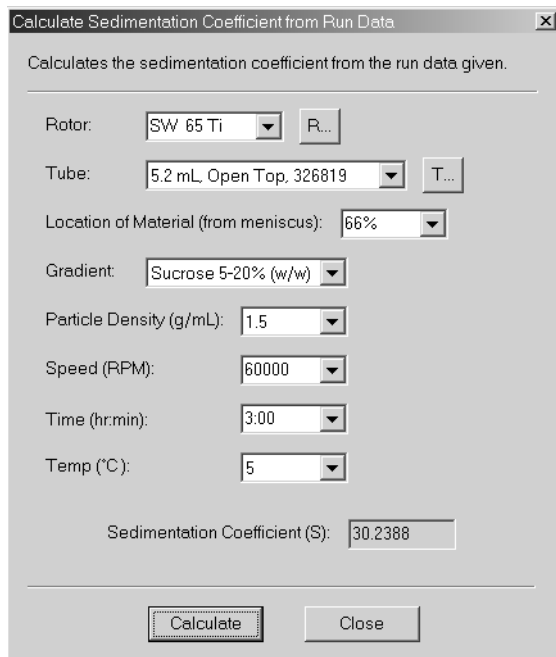

- 3 Press **Calculate** .  
The sedimentation coefficient (s) is displayed.
- 4 Note the calculated s, then press **Close** to close the window.

## Sedimentation Coefficient From Molecular Mass

Estimate the sedimentation coefficient given the molecular weights of the macromolecules.

### To calculate sedimentation coefficient:

- 1 Select **Sedimentation Coefficient from Molecular Mass** from the Calculate menu.
- 2 Select the macromolecule.

- 
- 3 Enter the molecular mass or molecular length of the molecule (see [Figure 2.30](#)).

**Figure 2.30** Estimate Sedimentation Coefficient from Molecular Mass Screen

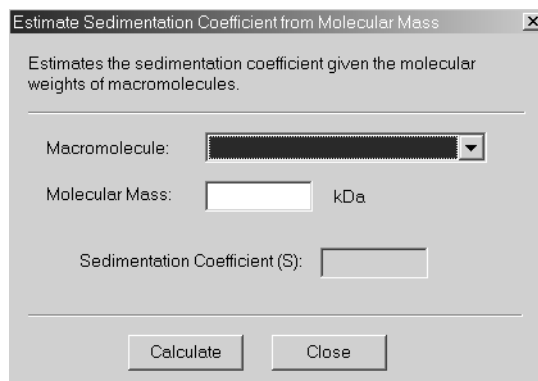

Estimate Sedimentation Coefficient from Molecular Mass

Estimates the sedimentation coefficient given the molecular weights of macromolecules.

Macromolecule:

Molecular Mass:  kDa

Sedimentation Coefficient (S):

Calculate Close

- 
- 4 Press **Calculate**.
- The sedimentation coefficient is displayed.
- 
- 5 Note the calculated  $s$ , then press **Close** to close the window.
- 

## Restore Windows

---

If multiple windows are open (such as calculations, simulations, logs, rotor or tube lists), you can close all windows and return to the Settings window at any time by selecting **Restore Windows** from the Window menu.



## Using Simulation Features

---

When running a separation using CsCl, it is critical to keep the salt from precipitating out and potentially causing a rotor mishap. This is accomplished by running the rotor below the speed at which the salt precipitates. ESP (Efficient Sedimentation Program) was developed as a way of predicting optimum run conditions for pelleting RNA over a wide variety of rotor and tube combinations. ESP accomplishes this by calculating the movement of three components in solution:

- RNA, ranging in size from 0.1 to 3kb,
- A hypothetical contaminant of chromosomal DNA, and
- CsCl

Movement of each component is monitored as a function of speed and considers the geometry of different rotor and tube combinations. The program starts out at the maximum rated speed of the rotor (less if the overall solution density exceeds the limit of the rotor/tube combination selected), and simulates a sequence of steps reducing the speed of the rotor just prior to precipitation of the CsCl.

You access the simulations windows from the Simulate menu shown in [Figure 3.1](#). You can transfer the optimized run program generated from these simulated run parameters to the Settings window and start the run, or save the simulation for later use. You can also print out the simulation (see [APPENDIX A, Preinstallation Requirements](#), for printer hookup instructions).

**Figure 3.1** Simulate Menu

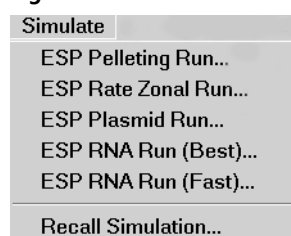

## ESP Pelleting

---

Pelleting separates particles of different sedimentation coefficients, the largest particles in the sample traveling to the bottom of the tube first. ESP simulates the formation of gradient and

separation of sample components to determine the shortest possible run duration that precludes precipitation. The simulation predicts the time at which the required separation will be achieved. If a step gradient instead of a linear gradient is used, the sample will migrate faster toward the tube bottom.

**To set up ESP pelleting:**

1 Select **ESP Pelleting Run** from the Simulate menu.

2 Enter the sedimentation coefficient of the particle of interest (see [Figure 3.2](#)).

**NOTE** Sedimentation coefficient value reported is usually  $s_{20, w}$ , which means 20°C in water. If the run temperature is set to other than 20°C, the  $s$  value must be adjusted for the temperature difference.

**Figure 3.2** ESP Pelleting Screen

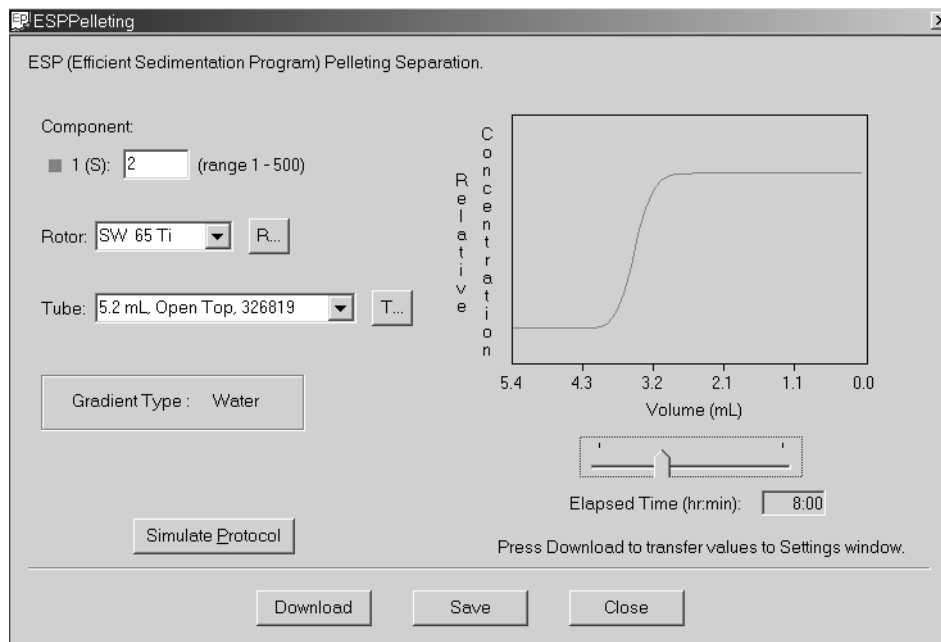

3 Select the rotor and tube in use.

4 Press **Simulate Protocol**.

The simulation is graphically displayed, showing the movement of the solute as it pellets. Time required for the separation is shown in the Elapsed Time (hr:min) field. (Use the slide bar to display pelleting at shorter run times.) You can transfer these settings to the Settings window and start the run, or save the simulation for later recall.

**NOTE** To save the program for future recall, press **Save**, then enter a program name in the dialog box. If the program is a modification of a previously saved program that you want to retain, you can save the new version under a different name by selecting **Save As** from the File menu.



- 5 Press **(Download)** to transfer the run parameters to the Settings window. If not saved to a specific filename, the program is automatically saved to a temporary file called LastESPPelleting.spr.
- 6 Press **(Enter)**, then **(Start)** to run the program.

## ESP Rate Zonal

Particle separation achieved with rate zonal separation is a function of the particles' sedimentation coefficient and density, and the viscosity of the gradient material. Under centrifugal force, particles migrate as zones. Rate zonal separation is time dependent. ESP simulates the formation of gradient and separation of sample components as a function of time and radial position.

### To set up an ESP rate zonal run.

- 1 Select **ESP Rate Zonal Run** from the Simulate menu.
- 2 Enter the sedimentation coefficients of up to three particles of interest (see [Figure 3.3](#)).

**NOTE** Sedimentation coefficient value reported is usually  $s_{20, w}$ , which means 20°C in water. If the run temperature is set to other than 20°C, the  $s$  value must be adjusted for the temperature difference.

**Figure 3.3** ESP Rate Zonal Screen

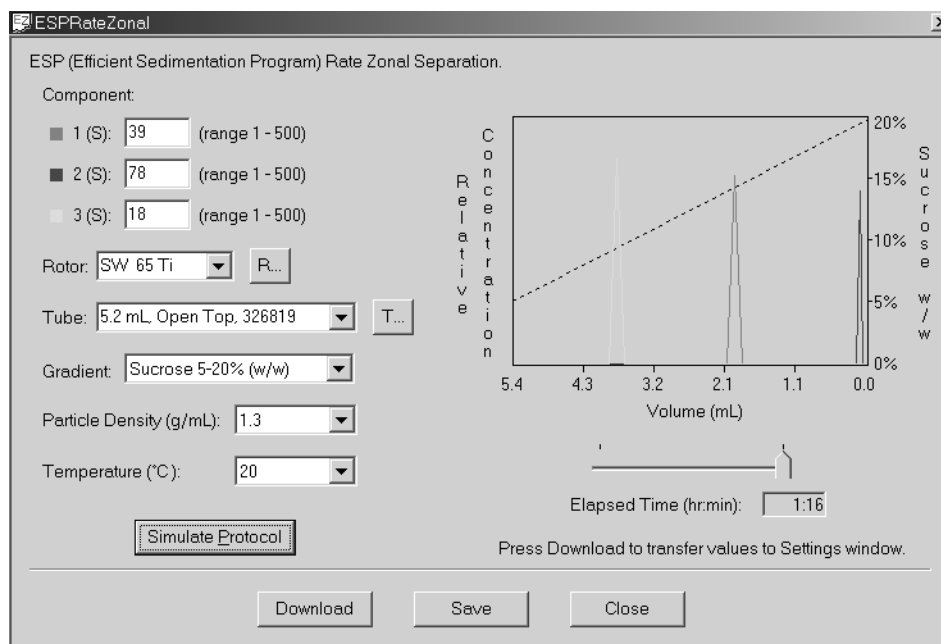

---

3 Select the rotor (swinging bucket only) and tube in use.

---

4 Select the gradient type.

---

5 Select the particle density.

---

6 Enter the run temperature.

---

7 Press **(Simulate Protocol)**.

The simulation positions the particle with the largest  $s$  value (fastest pelleting) at the bottom of the scale, and shows the relative positions of other selected particles along the tube length. The dotted line represents the gradient percentage. Time required for the separation is shown in the Elapsed Time (hr:min) window. (Use the slide bar to display conditions at shorter run times.) You can transfer these parameters to the Settings window and start the run, or save the simulation for later recall.

**NOTE** To save the program for future recall, press **(Save)**, then enter a program name in the dialog box. If the program is a modification of a previously saved program that you want to retain, you can save the new version under a different name by selecting **Save As** from the File menu.

---

8 Press **(Download)** to transfer the run parameters to the Settings window. If not saved to a specific filename, the program is automatically saved to a temporary file called LastESPRateZonal.err.

---

9 Press **(Enter)**, then **(Start)** to run the program.

---

## ESP Plasmid Run

---

Simulates an optimized plasmid DNA separation in homogeneous 1.55 g/mL CsCl-EtBr at 25°C. The simulation predicts the time at which the required separation will be achieved.

### To set up an ESP plasmid run:

---

1 Select **ESP Plasmid Run** from the Simulate menu.

- 2 Select the plasmid size (see Figure 3.4).

**Figure 3.4** ESP Plasmid Run Screen

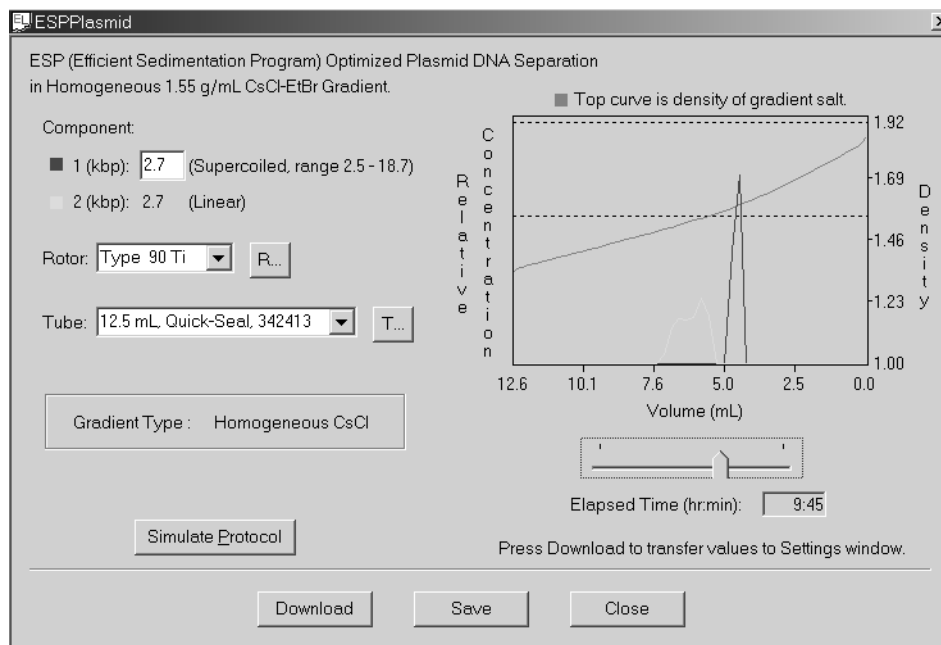

- 3 Select the rotor and tube in use from the drop-down menu.

- 4 Press **Simulate Protocol**.

The simulation is displayed on the graph.

- The green and blue curves represent the relative concentration of linear and supercoiled DNA, respectively.
- The red curve represents the density of the CsCl gradient with respect to the right-hand scale.
- The dotted line at the top of the graph represents the concentration at which CsCl will precipitate.
- The dotted line near the middle of the graph represents the initial density (1.55 g/mL) of the gradient.

Time required for the maximized separation is shown in the Elapsed Time (hr:min) window. You can use the slide bar to display separations at shorter run times. When you find the required separation with the shortest run time you can transfer these parameters to the Settings window and start the run, or save the simulation for later recall.

**NOTE** To save the program for future recall, press **Save**, then enter a program name in the dialog box. If the program is a modification of a previously saved program that you want to retain, you can save the new version under a different name by selecting **Save As** from the File menu.

- 5 Press **(Download)** to transfer the run parameters to the Settings window. If not saved to a specific filename, the program is automatically saved to a temporary file called LastPlasmid.pla.
- 6 Press **(Enter)**, then **(Start)** to run the program.

## ESP RNA (BEST)

Two simulations are provided for the pelleting of RNA molecules in the range 0.1 to 3.0 kbp through a cushion of 5.7 M CsCl at 25°C in a swinging bucket rotor. The RNA (Best) simulation, of a sample suspended in 2.91 M CsCl containing 4 M GuSCN layered over a CsCl cushion occupying one-third of the tube volume, is optimized for purity.

### To set up an ESP RNA (Best) run:

- 1 Select **ESP RNA Run (Best)** from the Simulate menu.
- 2 Select the particle length (see [Figure 3.5](#)).

Figure 3.5 ESP RNA (Best) Screen

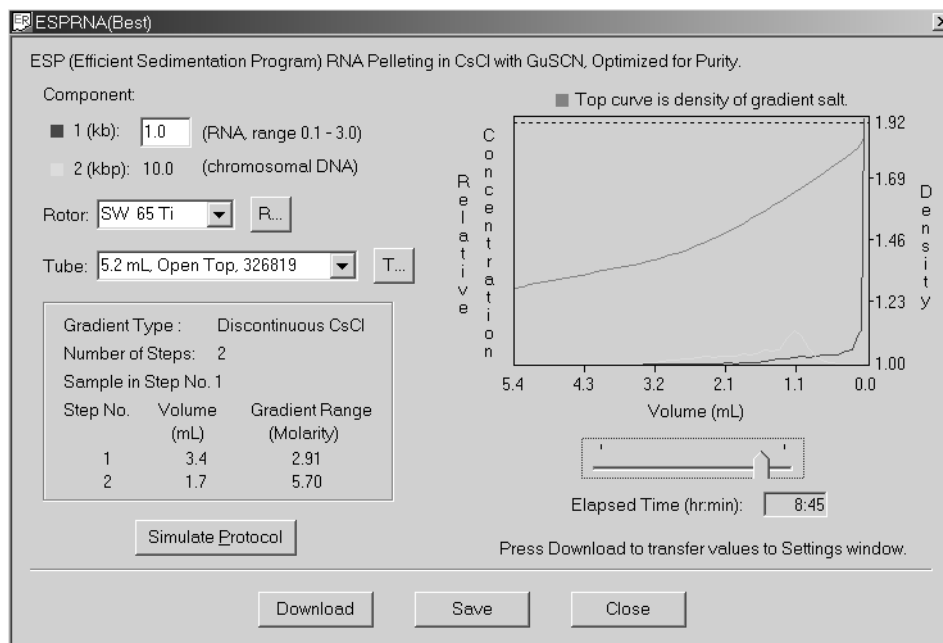

- 3 Select the rotor (swinging bucket only) and tube in use.

---

4 Press **Simulate Protocol**.

The simulation is displayed on the graph.

- The green and blue curves represent the relative concentration of linear and supercoiled DNA, respectively.
- The red curve represents the density of the CsCl gradient with respect to the right-hand scale.
- The dotted line at the top of the graph represents the concentration at which CsCl will precipitate.

Time required for the maximized separation is shown in the Elapsed Time (hr:min) window. You can use the slide bar to display separations at shorter run times. When you find the required separation with the shortest run time, you can transfer these parameters to the Settings window and start the run, or save the simulation for later recall.

**NOTE** To save the program for future recall, press **Save**, then enter a program name in the dialog box. If the program is a modification of a previously saved program that you want to retain, you can save the new version under a different name by selecting **Save As** from the File menu.

---

5 Press **Download** to transfer the run parameters to the Settings window.

---

6 Press **Enter**, then **Start** to run the program. If not saved to a specific filename, the program is automatically saved to a temporary file called LastESPRNA(Best).rnb.

---

## ESP RNA (Fast)

---

The RNA (Fast) simulation, of a sample suspended in 4 M GuSCN without CsCl layered over a CsCl cushion occupying one-fourth of the tube volume, is optimized for speed.

### To set up an ESP RNA (Fast) run:

---

- 1 Select **ESP RNA Run (Fast)** from the Simulate menu.

---

- 2 Enter the particle length (see [Figure 3.6](#)).

---

- 3 Select the rotor (swinging bucket only) and tube in use.

Figure 3.6 ESP RNA (Fast) Screen

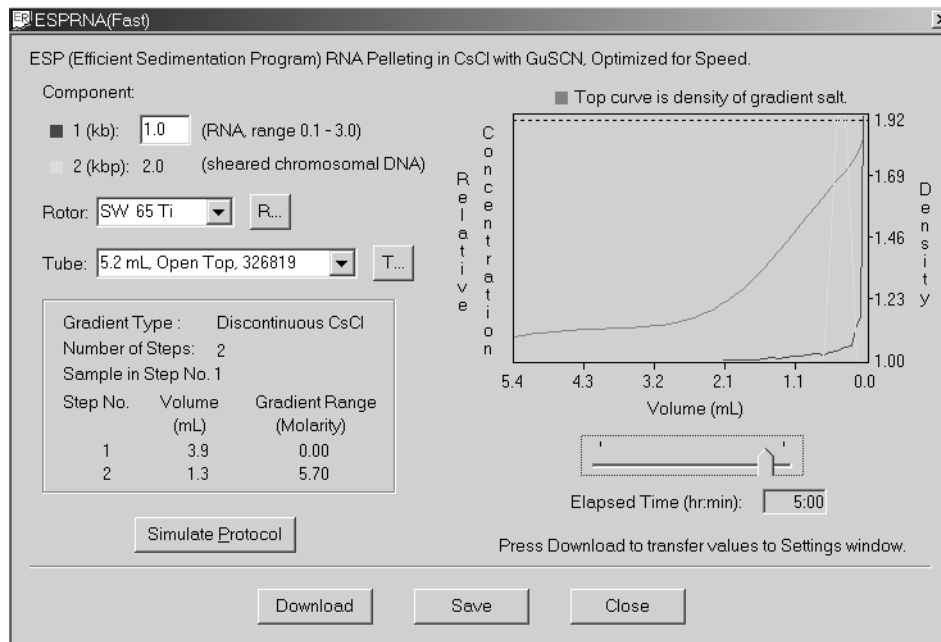

4 Press **(Simulate Protocol)**.

The simulation is displayed on the graph.

- The green and blue curves represent the relative concentration of linear and supercoiled DNA, respectively.
- The red curve represents the density of the CsCl gradient with respect to the right-hand scale.
- The dotted line at the top of the graph represents the concentration at which CsCl will precipitate.

Time required for the maximized separation is shown in the Elapsed Time (hr:min) window. You can use the slide bar to display separations at shorter run times. When you find the required separation with the shortest run time, you can transfer these parameters to the Settings window and start the run, or save the simulation for later recall.

**NOTE** To save the program for future recall, press **(Save)**, then enter a program name in the dialog box. If the program is a modification of a previously saved program that you want to retain, you can save the new version under a different name by selecting **Save As** from the File menu.

5 Press **(Download)** to transfer the run parameters to the Settings window. If not saved to a specific filename, the program is automatically saved to a temporary file called LastESPRNA(Fast).rnf.

6 Press **(Enter)**, then **(Start)** to run the program.

## Recall Simulation

---

You can recall previously saved simulations that you want to reuse or modify.

---

**1** Select **Recall Simulation** from the Simulate menu.

---

**2** Select the simulation you want to recall.

---

**3** Press **(Open)** to open the simulation.

---

**4** Press **(Download)** to transfer the run parameters to the Settings window.

**NOTE** You can modify the program before running it, but changes will not be saved unless you save the altered program under a new name.

---

**5** Press **(Enter)**, then **(Start)** to run the program.

---





# Reference and Log Functions

## Reference Features

---

The Optima eXPert software provides reference functions (see [Figure 4.1](#)) to facilitate the ultracentrifugation process. Among the features are:

- A rotor catalog that lists Beckman Coulter preparative ultracentrifuge rotors by rotor type.
- A rotor library that lists the Beckman Coulter preparative ultracentrifuge rotors available at the user's site.
- A tube catalog that provides a list of all tubes used in Beckman Coulter preparative ultracentrifuge rotors.
- An interactive chemical resistances listing to provide general information about chemical interactions between equipment/accessories used in ultracentrifugation and various commonly used chemicals.

**Figure 4.1** Reference Menu

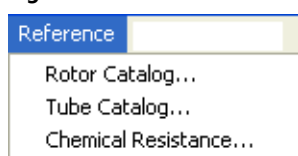

## Rotor Catalog

The rotor catalog lists all Beckman Coulter preparative ultracentrifuge rotors (see [Figure 4.2](#)). (Discontinued rotors are included in the catalog for the benefit of customers still using them—the discontinued date appears in the Specification area of the window.) Rotors are grouped by type:

- swinging bucket, in which tubes are held in numbered rotor buckets attached to numbered positions on the rotor body
- fixed angle, in which tubes are held at an angle (usually 20 to 45 degrees) to the axis of rotation in numbered tube cavities
- near vertical tube, in which tubes are held at a reduced angle (typically 7 to 10 degrees) to the axis of rotation in numbered cavities; the reduced tube angle reduces run time from fixed angle rotors
- vertical tube, in which tubes are held parallel to the axis of rotation

Figure 4.2 Rotor Catalog Screen

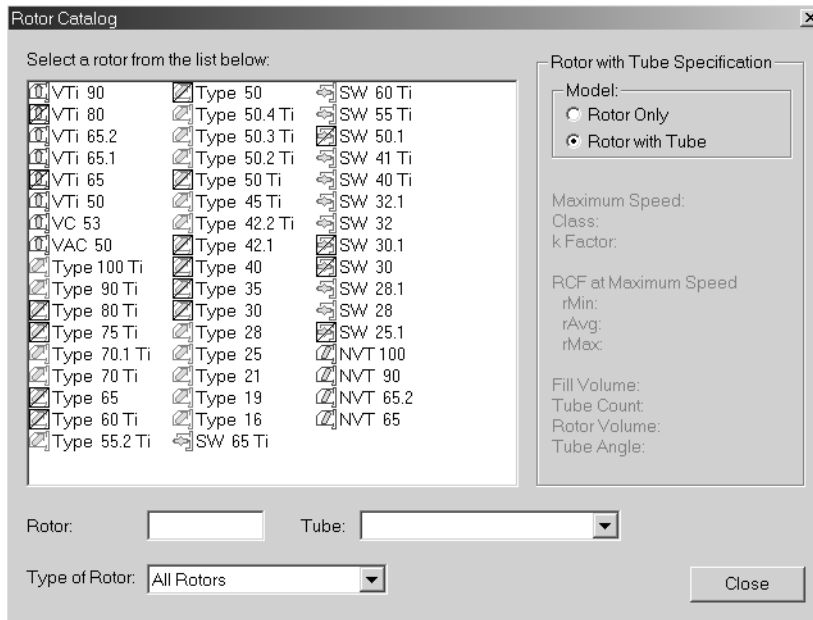

Rotor selection depends on a variety of factors, such as sample volume, number of sample components to be separated, particle size, required run time, required quality of separation, type of separation, and the ultracentrifuge in use. General information about ultracentrifuge rotor selection and use is in *Rotors and Tube for Beckman Coulter Preparative Ultracentrifuges (LR-IM)*; detailed information about the use and care of a specific rotor is contained in the applicable rotor manual.

**To use the rotor catalog:**

- 1 Select **Rotor Catalog** from the Reference menu. The rotor catalog lists all Beckman Coulter preparative ultracentrifuge rotors, grouped by rotor type. Rotors that are no longer manufactured have an X over the icon beside the rotor name.

**NOTE** To view a list of only one type of rotor, select from the Type of Rotor drop-down menu.

- 2 Select a rotor from the list (see [Figure 4.3](#)). You can display specifications for the rotor only, or for a specific rotor and tube combination by pressing the applicable radio button in the Specification area.
- 3 You can select a different tube that may be used with the selected rotor from the Tube drop-down menu. The specifications for the selected tube will be displayed in the Specification area.
- 4 Press **Close** to close the window.

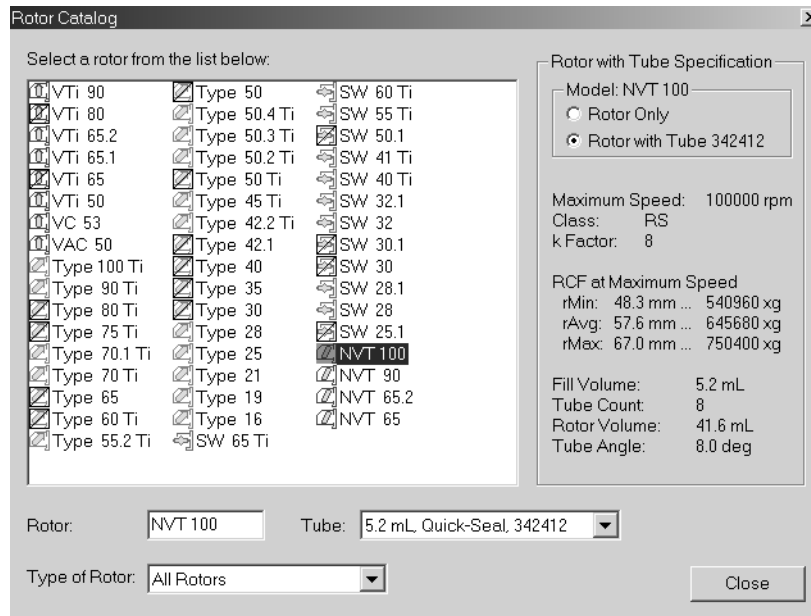
**Figure 4.3** Selected Rotor Specifications

## Rotor Library

The rotor library is created by the user to list the Beckman Coulter preparative ultracentrifuge rotors that are available at the user's site. Rotors in the rotor library appear in the rotor drop-down menu of each setup window with a rotor option (see [Figure 4.4](#)). Create or edit the rotor library as follows:

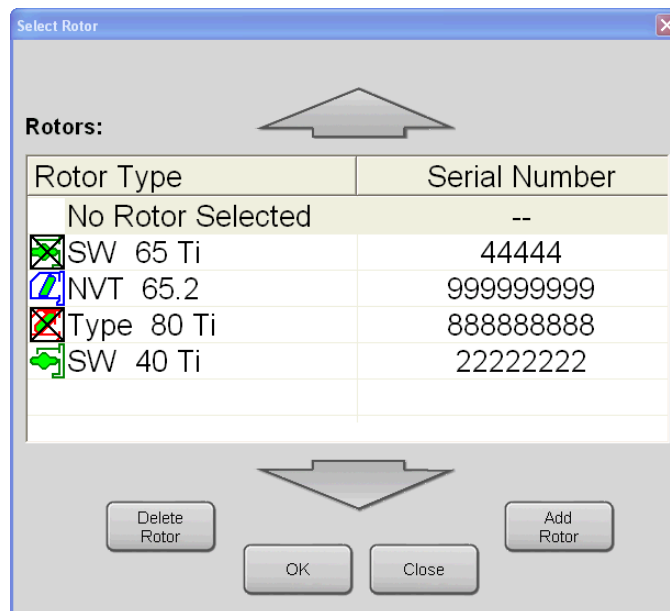
**Figure 4.4** Select Rotor Screen

**To add a rotor to the rotor library:**

- 1 From the Settings screen, press the **Select Rotor** button. The Select Rotor screen appears.
- 2 From the Select Rotor screen, press the **Add Rotor** button. The Select from Rotor Catalog screen appears.
- 3 In the Rotor Catalog list to the left of the screen, select a rotor name and press the **OK** button. The Enter Rotor Serial Number screen appears as shown in [Figure 4.5](#).

**Figure 4.5** Enter Rotor Serial Number Screen

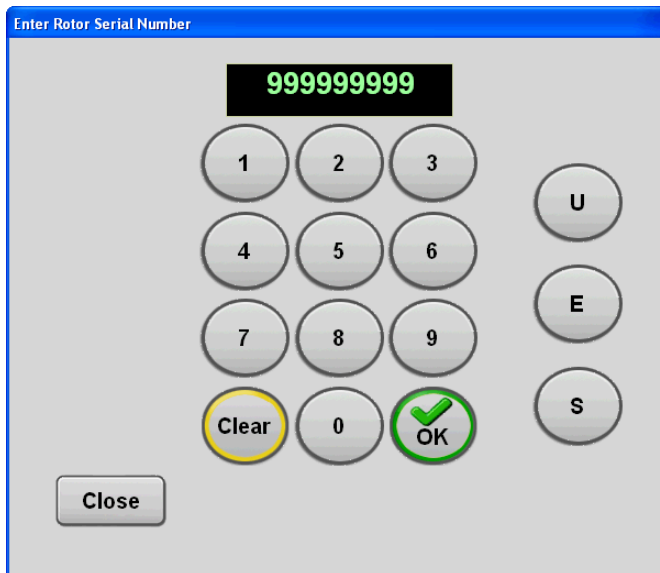

- 4 Enter the serial number (up to 9 digits in length) on the keypad, and press the **OK** button to accept. The Select Rotor screen returns to view, and the rotor type is added to the list.
- 5 Press the **OK** button to close the window. The Settings screen returns to view. To add another rotor type, repeat Steps 1 to 5.

**To delete a rotor from the rotor library:**

- 1 From the Settings screen, press the **Select Rotor** button. The Select Rotor screen appears.
- 2 From the Select Rotor screen, select a rotor type from the list and press the **Delete Rotor** button. The rotor type is removed from the list.

- Press the **OK** button to close the window. The Settings screen returns to view. To delete another rotor type, repeat Steps 1 to 3.

## Tube Catalog

The tube catalog (see [Figure 4.6](#)) lists Beckman Coulter tubes used in preparative ultracentrifuge rotors. Tube selection depends on a variety of factors, such as sample volume, number of sample components to be separated, particle size, required run time, required quality of separation, type of separation, and the rotor and ultracentrifuge in use. General information about tube selection and use is in *Rotors and Tubes for Beckman Coulter Preparative Ultracentrifuges* (LR-IM), and tube ordering information is in the *Ultracentrifuge Rotors, Tubes and Accessories Catalog* (BR-8101, available at [www.beckmancoulter.com](http://www.beckmancoulter.com)). Tubes are grouped in the catalog by type—OptiSeal, Quick-Seal, open-top, and konical. The tube type is indicated by an icon beside the tube name. You can view the specifications of a listed tube using the following procedure.

**Figure 4.6** Tube Catalog

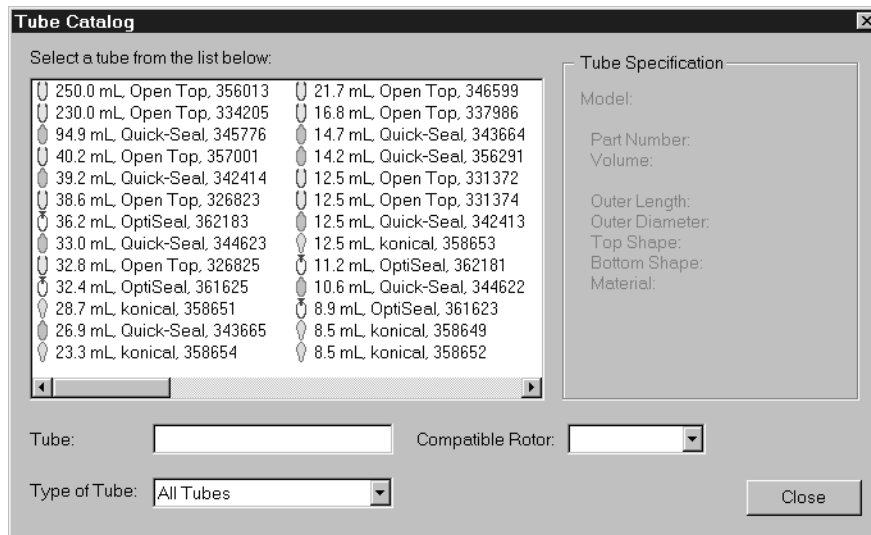

### To use the tube catalog:

- Select **Tube Catalog** from the Reference menu.
- Select a tube from the list (see [Figure 4.7](#)). The specifications for the selected tube will be displayed in the Tube Specification area.

**NOTE** To view a list of only one type of tube, select from the Type of Tube drop-down menu.

Figure 4.7 Selected Tube Specifications

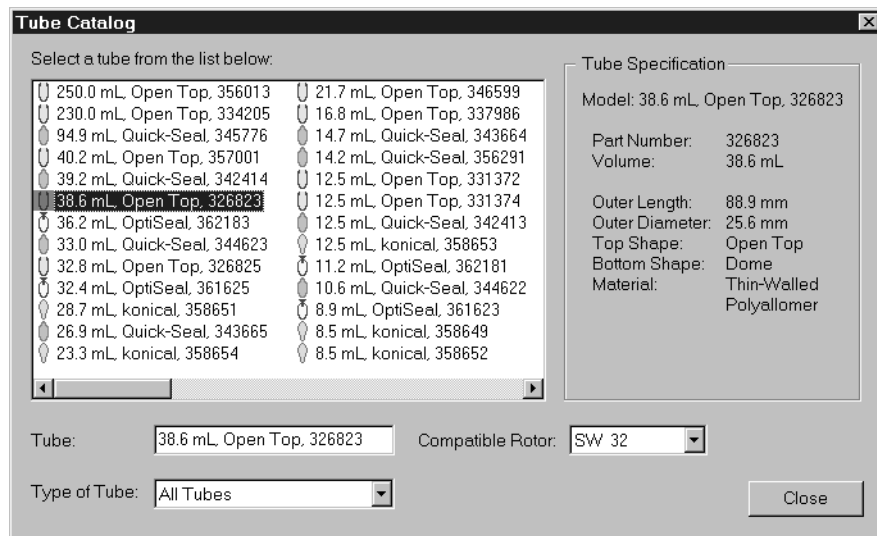

3 You can view a list of rotors that use the selected tube from the Compatible Rotor drop-down menu.

4 Press **Close** to close the window.

## Chemical Resistances

The chemical resistances list provides general information about the chemical interaction between equipment and accessories used in ultracentrifugation and various commonly used chemicals. A complete list of materials and chemicals is in *Chemical Resistances* (publication IN-175), available at [www.beckmancoulter.com](http://www.beckmancoulter.com).

Materials that have unsatisfactory or marginal resistance to the high concentrations used for these tests may still be usable in very low (that is, millimolar) concentrations. Soak tests at 1 g (at 20°C) established the data for most of the materials; reactions may vary under the stress of centrifugation, or with extended contact or temperature variations. Therefore, to prevent tube or bottle failure and sample loss, all solution/accessory combinations should be tested under operating conditions before use.



**The information provided in the table is from references, from current literature, or from research done by Beckman Coulter, and is only a guide for the proper selection of materials. No guarantee of safety based on these recommendations is expressed or implied. Many of the chemicals are explosive when concentrated or dry, or are toxic, caustic, allergenic, or carcinogenic. Always observe proper handling.**

**To use the chemicals list:**

- 1 Select **Chemical Resistances** from the Reference menu.
- 2 Press the **Chemicals** button to see a list of all chemicals represented in the database (see [Figure 4.8](#)), or select a subset of chemicals to be displayed from the Type of Chemical drop-down menu.

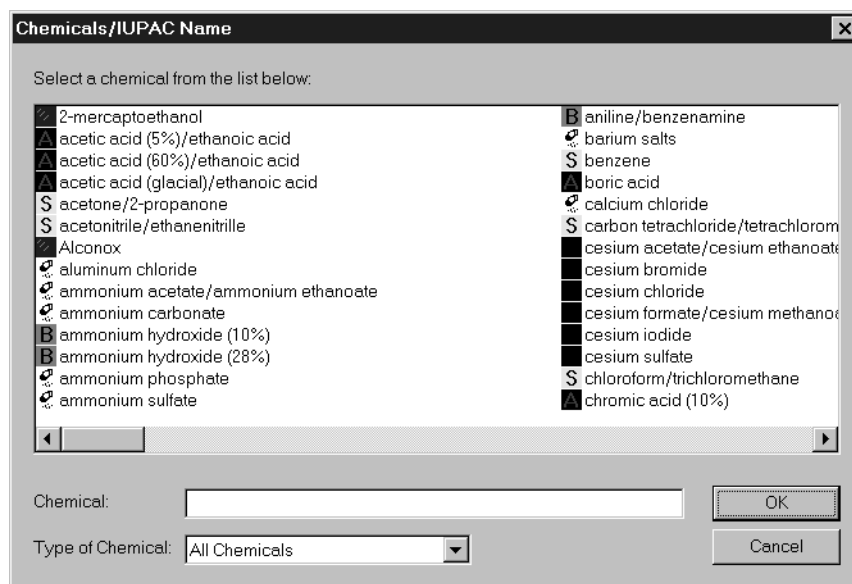
**Figure 4.8** Chemicals/IUPAC Name Screen

The chemicals are listed alphabetically by their most common name. Where applicable an IUPAC (International Union of Pure and Applied Chemistry) name is shown to the right of a trivial chemical name. Chemicals listed are either undiluted liquids or saturated (unless otherwise noted) aqueous solutions.

- 3 Select a chemical from the list and press **OK**.
- 4 Select the appropriate tab for the category of ultracentrifugation accessory (Tubes; Caps, Spacers, Rotors; O-rings, Adapters, Seals; Tubing; Finishes).  
Materials within the selected category are listed, together with the symbol for the material's chemical resistance (see [Figure 4.9](#)) to the selected chemical. Explanation of the symbols is shown in the area to the right of the list.

Figure 4.9 Chemical Resistances Screen

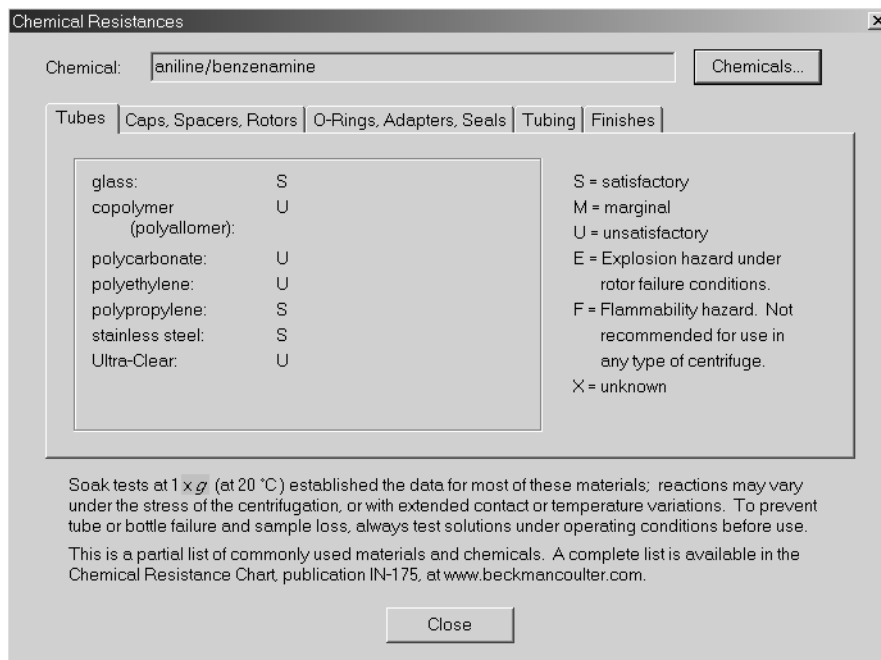

- 5 Press the **Chemicals** button to select another chemical or press **Close** to close the window.

## Exporting Data

The ultracentrifuge automatically saves data associated with each run that may be exported to a memory device. The memory device is connected to the USB port on the top of the instrument Control Head (see Figure 4.10). The exported data may be opened in a spreadsheet program such as Microsoft Excel. To optimize instrument performance, it is recommended that you periodically export the data and delete data files.

**NOTE** You must have an external memory device connected to the USB port before attempting to export data.

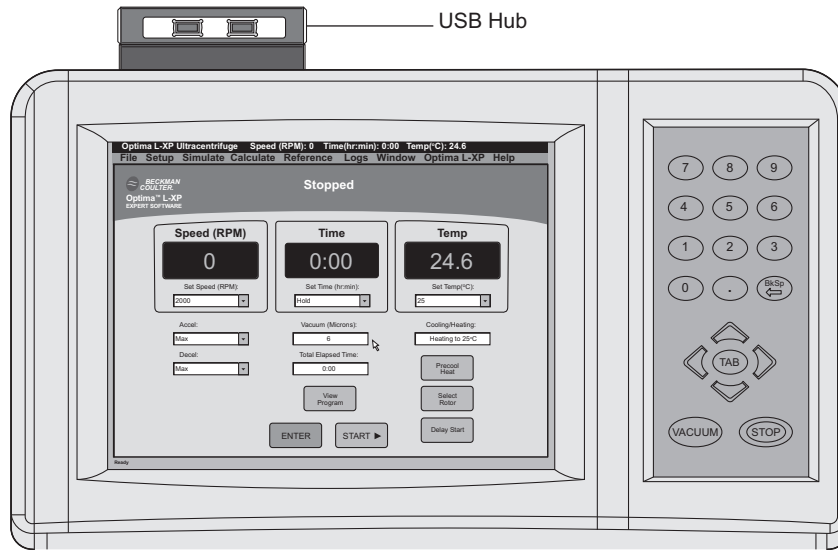

**Figure 4.10** Optima L-XP Control Head with USB Hub**To export data:**

- 1 On the Settings screen, select **Export Data** from the Optima L-XP drop-down menu. The Export Data screen appears as shown in [Figure 4.11](#).

**Figure 4.11** Export Data Screen

- 2 Enter a file name up to 20 characters in length on the keypad. Uppercase letters are default. To enter lowercase letters, press the **(Shift)** key. Press **(Back)** to erase entered characters one at a time. To clear the entire entry, press **(Clear)**.

- 3 Press the **Clear** button. The Export Data screen closes when the export is complete, after which the memory device can be safely removed from the USB port.

## Log Features

The Logs menu (see [Figure 4.12](#)) provides access to the Instrument Usage Log, Display Last Run Record log, and the Print Last Run Record Automatically option.

**Figure 4.12** Logs Menu

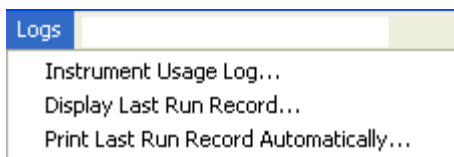

### Instrument Usage Log

Instrument usage is logged during each ultracentrifuge run. Each Instrument Usage Log includes the user name and date, the time the run was started, the type of run, the name of the program, the rotor ID and serial number, the stop condition (run completed, stopped by operator, or stopped by diagnostic), maximum speed reached (in rpm), total run time (a multistep run is considered one run; maximum speed and total run time for all steps is given), total  $\omega^2t$ , the rotor temperature at the end of the run, run comments for batch and lot information, and the acceleration and deceleration profiles for the run. The log may be printed out; see [APPENDIX A, Preinstallation Requirements](#), for printer hookup instructions.

#### To print an instrument usage log:

- 1 Select **Instrument Usage Log** from the Logs menu.
- 2 Select **Print** from the File menu to print the entire log, or select a run and press **View Details**, then select **Print** to print a specific run.

### Display Last Run Record

Complete run information is logged when the run ends (a multistep run is considered one run), and is viewed by selecting Display Last Run Record. The run record (see [Figure 4.13](#)) includes the user name, rotor ID, free-text comments, and diagnostic codes. This log may be printed to maintain a permanent record for regulatory or lab processes purposes. You can have each run record

automatically printed upon run completion by selecting **Print Last Run Record Automatically** from the Logs menu (see [APPENDIX A, Preinstallation Requirements](#), for printer hookup instructions).

**NOTE** The settings for a run are logged when the run starts.

**Figure 4.13** Run Record

Optima L-100 XP Run Record

GENERAL INFORMATION

<b>Start Date Time</b>	<b>Type of Run</b>	<b>Name of Program</b>	<b>Rotor Model</b>	<b>Tube</b>
6/10/04 6:11:53 AM				
<b>Instrument Serial #</b>	<b>Rotor Serial #</b>			
_____	_____			

RUN SYNOPSIS

Run completed

RUN CONDITION

	<b>Maximum Speed</b>	<b>Total Run Time</b>	<b>Total w2t</b>	<b>Temp At End Of Run</b>
	28000	1:00 (hr:min)	3.08e+010	5.0
	<b>Accel Profile</b>	<b>Decel Profile</b>		
	Max	Max		
<u>Step 1</u>	<b>Set Speed</b>	<b>Actual Speed</b>	<b>Set Temp</b>	<b>Temp At End of Step</b>
	28000	28000	4°C	5.0°C
	<b>Set Time</b>	<b>Actual Run Time</b>	<b>w2t</b>	
	1:00 (hr:min)	1:00 (hr:min)	3.08e+010	

OPERATOR: \_\_\_\_\_



# Troubleshooting

## Introduction

---

*This chapter lists possible malfunctions, together with probably causes and corrective actions. Maintenance procedures are given in [CHAPTER 6, Care and Maintenance](#). For any problems not covered here, call Beckman Coulter Customer Service at 1-800-742-2345 (U.S.A. or Canada); or contact your local Beckman Coulter Representative for assistance.*

**NOTE** It is your responsibility to decontaminate the instrument, as well as any rotors and/or accessories, before requesting service by Beckman Coulter Field Service.

## User Messages

---

Informational messages and setup prompts are displayed in the Status window or on the status line at the screen bottom. If an abnormal condition arises, a Diagnostics window appears. The problem and a recommended corrective action are displayed in the window. After correcting the problem, press **Clear** to clear the diagnostic and close the window. (The message will reappear if the problem still exists.)

If the message provides cautionary information only, the run continues uninterrupted. For example, if the speed setting is higher than the speed permitted by the rotor overspeed disk, the speed will be lowered to the maximum rated speed and a diagnostic message will indicate that the change has been made. If a serious problem arises, the instrument will shut down with or without the brake, depending on the problem. If necessary, the power will automatically trip. Corrective action will be displayed.

Refer to [Table 5.1](#) to determine the nature of the condition and any recommended actions. If a problem persists after you have performed the recommended action, call Beckman Coulter Field Service at 1-800-742-2345 (U.S.A. or Canada); outside the U.S., contact your local Beckman Coulter Representative.

Table 5.1 Diagnostic Message Chart

Diagnostic Category/ Range	Possible Cause	User Action
<b>SPEED</b> 3X	Speed has been set above maximum allowed; or wrong, damaged, or missing overspeed disk	Check set speed; check for clean, undamaged, and correct overspeed disk (see <i>Rotors and Tubes</i> for replacement instructions).
<b>TEMPERATURE</b> 5X	Temperature control or vacuum system malfunctioning	Check the air inlet (at bottom of the front panel) for obstructions. Call Beckman Coulter Field Service.
<b>DRIVE</b> 6X	Abnormal change in drive speed or overheated drive  Erroneous signal from tachometer board to display board or drive system problem. Door lockout time may not be sufficient to prevent access to spinning rotor.	Be sure a rotor is properly installed on the spindle; if power has failed, wait for 5 minutes for drive to cool; check for air inlet obstruction.  Call Beckman Coulter Field Service and wait 4 hours before attempting to open if display shows 0 RPM immediately after failure.
<b>VACUUM</b> 4X	Vacuum not being drawn properly	Check door O-ring for damage and cleanliness; check for excessive moisture; turn the vacuum on for a few hours or overnight; check rotor lid O-rings for possible leakage.
<b>IMBALANCE</b> 7X	Rotor imbalance (at low speeds)	Check for proper rotor loading.
<b>DOOR</b> 8X	Door is open when the <b>(Start)</b> key is pressed	Be sure door is closed.
<b>POWER</b> 2X	Loss of power during run	Check TIME display; Run may need to be restarted or aborted.
<b>CPU</b> 1X or 9X	Microprocessor malfunction or loss of program memory	No user action. Call Beckman Coulter Field Service.
<b>COMM</b>	Communication lost between the user interface and the instrument control	No user action. Call Beckman Coulter Field service.
	There is no default printer set when <b>Automatically Print a Run Record</b> was selected	Set up printer under File menu.

## Retrieving Your Sample in Case of Power Failure

---

If a power failure occurs during a run, the rotor begins to decelerate with the brake off. If the rotor is still spinning above 1000 RPM when power is restored, the instrument will resume operation and the rotor will return to set speed. A diagnostic message will alert you that a power outage occurred.

If the rotor is spinning below 1000 RPM when power is restored,

- In TIME mode, the timer resets to the original time setting and starts counting down.
- In HOLD mode, the timer resets to zero and starts counting up.
- In ESP or multi-step mode, the system repeats the step during which the power failure occurred, from the beginning of that step.

If a power failure lasts for several hours, it may be necessary to retrieve the sample from the rotor. (A rotor decelerating without the brake may take hours to come to a complete stop.) To gain access to the rotor, it will be necessary to remove the control head cover and front panel to disengage the door lock.

 **WARNING**

**Any maintenance procedure requiring removal of a panel exposes the operator to the possibility of electrical shock and/or physical injury. Therefore, turn the power off (O) and disconnect the instrument from the main power source by removing the Mains (power) plug from the outlet receptacle, and refer such maintenance to qualified service personnel.**

 **WARNING**

**NEVER attempt to slow or stop the rotor by hand.**

 **WARNING**

**The following procedure should be performed only when absolutely necessary and only by qualified service personnel.**

**To remove a sample upon power failure:**

---

- 1 Remove the key from the key switch and turn the power switch to off position before trying to slide the control head cover off the instrument.

---

- 2 Locate the two metal latches (see [Figure 5.1](#)) at the lower outside corners on the back of the control head. Use your fingers to depress the latches to disengage the cover from the control head.

---

- 3 With both hands, lift it slightly and pull it toward you, until it is free (approximately 1 to 1 1/2 inches), taking care not to disconnect or damage any of the attached cables.

**Figure 5.1** Removing the Control Head Cover

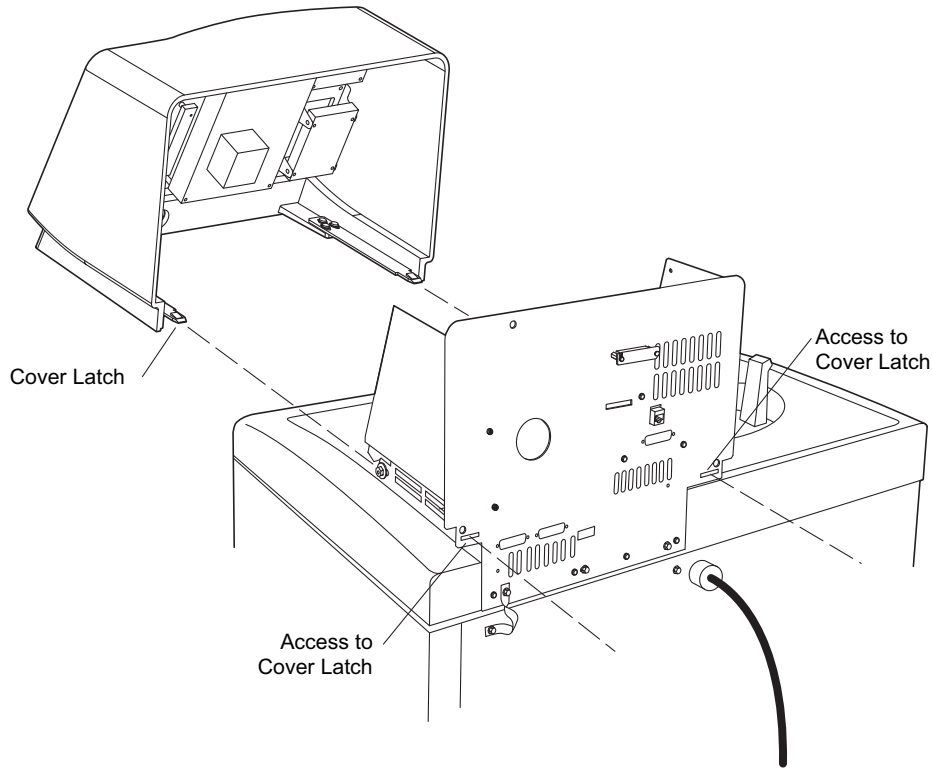

**4** To open the top cover, insert a #2 (0.25-inch diameter) Phillips-head screwdriver into the hole located in the front, center of the top cover (see [Figure 5.2](#)). Turn the screwdriver counterclockwise (to the left) until the screw bottoms out. Then, to release the latch, push the screwdriver inward. Once the latch is released, lift the top cover.

**5** Lift the front panel to free the bottom tabs that secure it in place.

**NOTE** In [Figure 5.1](#), the control head is shown separated from the instrument, and attached wires are not shown to provide detail of latches.

**! WARNING**

**After removing the panel, listen carefully for any sounds coming from the drive. Then touch the fan housing (see [Figure 5.3](#)) to feel if it is vibrating and listen again. Do not proceed if any sound or vibration is emitted from the housing.**

**6** Vent the vacuum chamber by slowly turning the small setscrew on the vacuum solenoid valve to the right (clockwise) as shown in [Figure 5.3](#) until you hear the air released into the chamber. If you hear a whining noise, close the valve and wait, because the rotor is still spinning.



**Figure 5.2** Depressing the Latch to Loosen the Front Panel

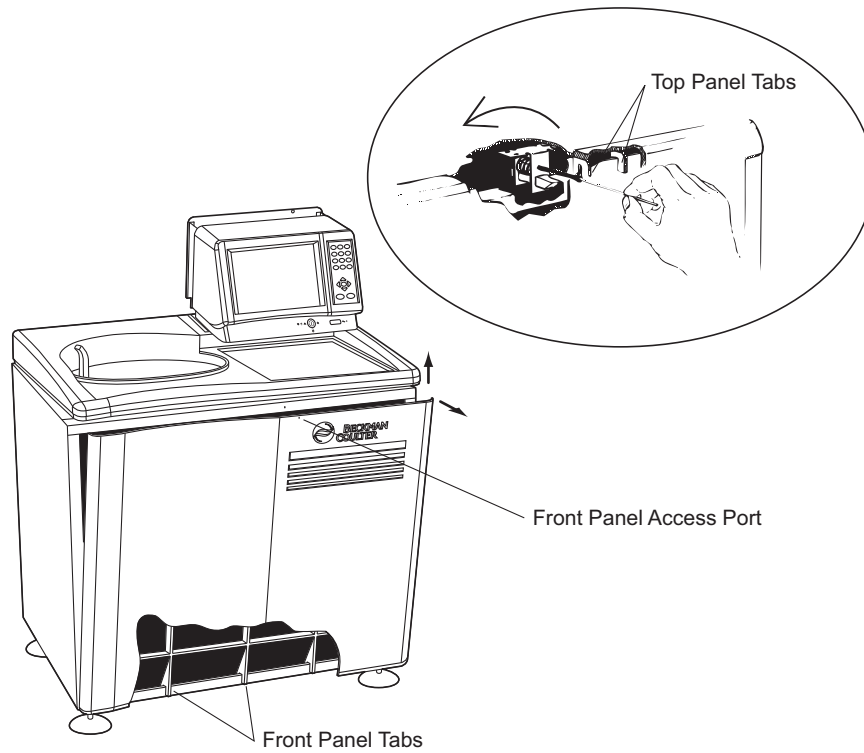

**Figure 5.3** Interior View of Instrument (Panel Removed)

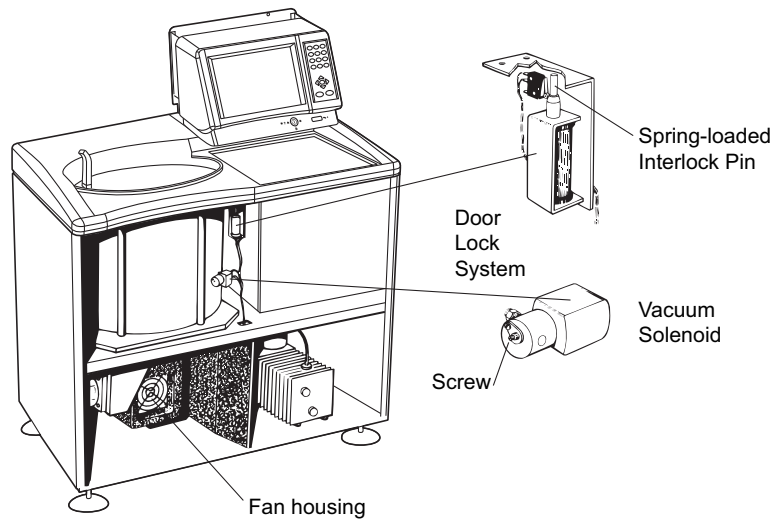

- 7** About 10 seconds after the hissing noise stops, turn the setscrew to the left (counterclockwise) until it stops.

- 8 Push down on the interlock pin with your finger (Figure 5.3) while opening the chamber door with your free hand. (If the rotor is still spinning, close the door and wait.) Be very careful not to touch any wires or circuitry.

**WARNING**

**Do not attempt to run the instrument before returning the front panel and control head cover to the correct position.**

- 9 After retrieving the sample, close the chamber door, then replace the front panel on the instrument. Insert the tabs at the bottom of the panel onto the lip at the base of the instrument, being sure to align the front panel with the side panels. (See Figure 5.4)

**Figure 5.4** Reinstalling the Front Panel

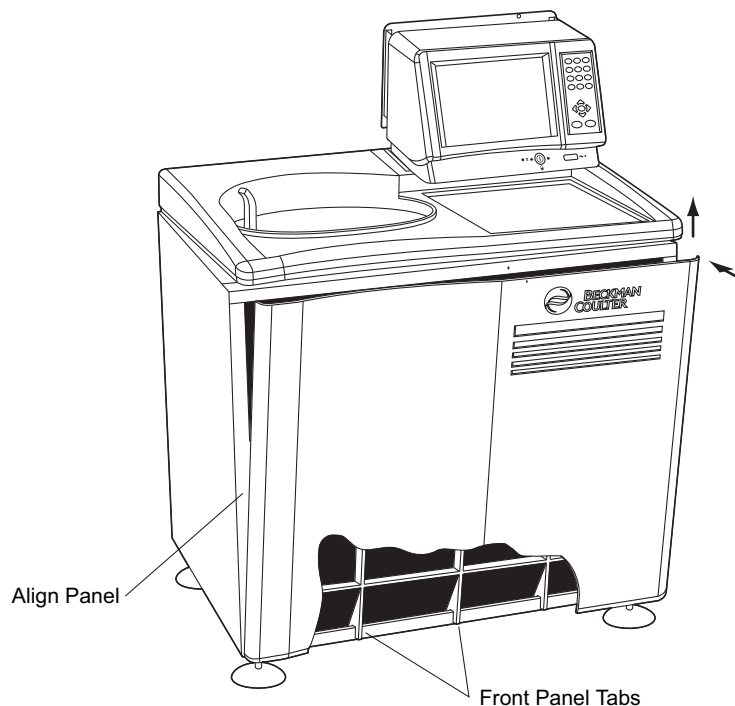

- 10 Lift the front edge of the top panel a few inches and insert the upper edge of the front panel under it. Push back gently to engage the tabs, then down to activate the latch.
- 11 Carefully replace the control head by sliding it along the small ridges provided. When the control head cover is correctly positioned, push it until the latches snap into place.
- 12 Return the key to the interlock switch.

# Care and Maintenance

## Introduction

---

*This chapter contains care and maintenance procedures that should be performed regularly. For maintenance not covered in this manual, call Beckman Coulter Customer Service at 1-800-742-2345 (U.S.A. or Canada); outside the U.S., contact your local Beckman Coulter Representative for assistance. User messages and recommended actions are discussed in [CHAPTER 5, Troubleshooting](#). Refer to the applicable rotor manual and Rotors and Tubes for instructions on the care of rotors and their accessories.*

**NOTE** It is your responsibility to decontaminate the instrument, as well as any rotors and/or accessories, before requesting service by Beckman Coulter Field Service.

 **WARNING**

**Any maintenance procedure requiring removal of a panel exposes the operator to the possibility of electrical shock and/or physical injury. Make sure that the power switch is off (O) and the ultracentrifuge is disconnected from the main power source by removing the Mains (power) plug from the outlet receptacle, and refer such servicing to qualified service personnel.**

## Cleaning

---

**NOTE** Before using any cleaning or decontamination methods except those recommended by the manufacturer, users should check with the manufacturer that the proposed method will not damage the equipment.

Clean instrument surfaces using a cloth dampened with a mild detergent solution such as Solution 555. Dilute the detergent with water (10 parts water to 1 part detergent). (Be careful not to spill liquid on the instrument where electrical or mechanical components could get damaged.)

## Rotor Chamber

The rotor chamber is coated with epoxy resin paint, and the chamber door O-ring is Buna N rubber. The chamber can be wiped clean with a cloth dampened with a mild detergent such as Solution 555. Dilute the detergent with water (10 parts water to 1 part detergent). The O-ring should be cleaned with a tissue or soft cloth every 3 or 4 months. Replace the O-ring whenever it becomes worn or

damaged. Lightly coat the O-ring with silicone vacuum grease (335148) before reinstalling it to ensure an optimum vacuum seal. (Instrument O-rings have not been designed as bioseals for aerosol containment.)

## Decontamination

---



If the instrument and/or accessories are contaminated with radioactive or pathogenic solutions, follow appropriate decontamination procedures as determined by your laboratory safety officer. Refer to *Chemical Resistances* (IN-175) or contact Beckman Coulter Field Service to ensure that the decontamination method does not damage any part of the instrument (or accessories).

## Sterilization and Disinfection

---

The top working surface is finished with urethane paint; the sides are finished with general purpose paint. Ethanol (70%) may be used on both these surfaces.



**Ethanol is a flammability hazard. Do not use it in or near operating ultracentrifuges.**

While Beckman Coulter has tested these methods and found that they do not damage the instrument, no guarantee of sterility or disinfection is expressed or implied. When sterilization or disinfection is a concern, consult your laboratory safety officer regarding proper methods to use.

## Storage and Transportation

---

To ensure that the instrument does not get damaged, contact Beckman Coulter Field Service for specific instructions and/or assistance in preparing the equipment for transport or long-term storage. Temperature and humidity requirements for storage should meet the environmental requirements described under *Specifications* in [CHAPTER 1, Description](#), of this manual.

## Supply List

---

Call Beckman Coulter Customer Service at 1-800-742-2345 (U.S.A. or Canada), or contact your local Beckman Coulter Representative for information about ordering parts and supplies. A partial list of supplies is given below for your convenience. See the Beckman Coulter *Ultracentrifuge Rotors, Tubes & Accessories* catalog (BR-8101, available at [www.beckmancoulter.com](http://www.beckmancoulter.com)) for detailed information on ordering rotors, tubes, and accessories.

### Replacement Parts

Description	Part Number
Chamber O-ring	801778
Hewlett-Packard Deskjet 940c Printer	963423

### Supplies

**NOTE** For MSDS information, go to the Beckman Coulter website at [www.beckmancoulter.com](http://www.beckmancoulter.com).

Description	Part Number
Silicone vacuum grease (2 oz)	335148
Solution 555 (1 qt)	339555
Logbook for preparative ultracentrifuges	330049
Master rotor logbook	339587



# Preinstallation Requirements

## Introduction

---

**NOTE** Do not attempt to install or turn on the power to the Optima L-XP. Its purchase price includes installation by Beckman Coulter personnel. Installation by anyone other than authorized Beckman Coulter personnel invalidates any warranty covering the instrument.

Preinstallation requirements may have been sent prior to shipment of the instrument. They are also available at [www.beckmancoulter.com](http://www.beckmancoulter.com). (Copies may also be attached to the outside of the shipping container.) The following information is provided in case the Optima L-XP must be relocated. Contact Beckman Coulter Field Service to adjust and level the instrument if it must be moved. (The pads on each leveling leg are designed to prevent possible rotation of the instrument in the case of a rotor mishap.)

## Space Requirements

---

 **WARNING**

**Do not place the ultracentrifuge near areas containing flammable reagents or combustible fluids. Vapors from these materials could enter the ultracentrifuge air system and be ignited by the motor. Maintain a 30-cm (1-ft) clearance envelope around the ultracentrifuge while it is running. No persons or any hazardous materials should be within this clearance boundary while the ultracentrifuge is operating except to change operating controls, if required.**

Locate the ultracentrifuge in a clean, safe, uncluttered environment. Provide a 5.1-cm (2-in.) clearance on each side of the instrument, as the feet extend about 5.1 cm (2 in.) beyond the instrument (see [Figure A.1](#)). (The pads under each foot are designed to prevent possible rotation of the instrument in the event of a rotor mishap.) A 15.2-cm (6-in.) clearance is required at the rear of the instrument for servicing and to ensure sufficient air ventilation. The ultracentrifuge must have adequate air ventilation to ensure compliance to local requirements for vapors produced during operation.

The Mains (power) plug is the disconnect device and must remain easily accessible. Position the instrument so that it is easy to remove the Mains (power) plug from the outlet receptacle.

The instrument will operate within specifications in a laboratory with ambient temperatures ranging from 10 to 40°C.

**Figure A.1** Dimensions of the Optima L-XP Ultracentrifuge

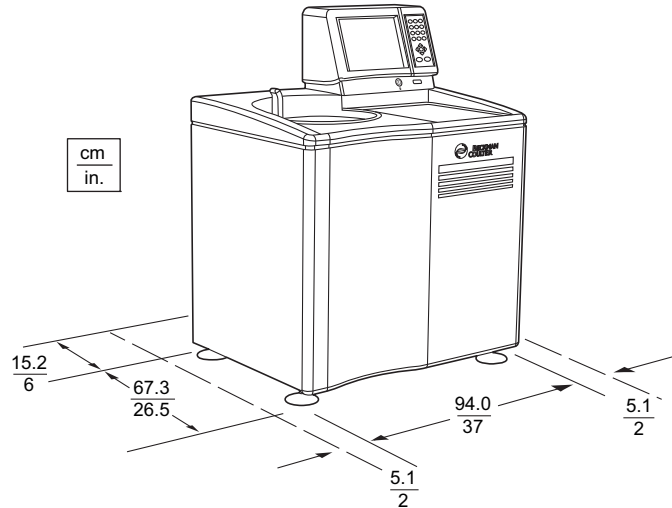

## Bio-Safety Level 3 Installation

For laboratories with epoxy aggregate floors, such as BSL-3 labs, a non-invasive installation kit (PN 393862) is available. The kit, which consists of a high-strength adhesive tape, is CSA certified for use on epoxyed aggregate floors only.

## Electrical Requirements

Instrument Rating:	220 to 240 VAC, 50 Hz, 20 A 200 to 240 VAC, 50/60 Hz, 20 A
Power Line Range:	180 to 264 VAC, 60 or 50 Hz (single-phase), 30 A

To reduce the risk of electrical shock, this equipment uses a three-wire electrical cord (1.8 m; 6 ft) and plug (see [Figure A.2](#)) to connect the equipment to earth ground. In regions where the instrument is supplied with an unterminated cord, a plug that meets local electrical and safety requirements must be supplied. (Contact your local Beckman Coulter office for specific information regarding these requirements.) See [Table A.1](#) for the required wire connections. Make sure that the matching wall outlet receptacle is properly wired and earth-grounded.



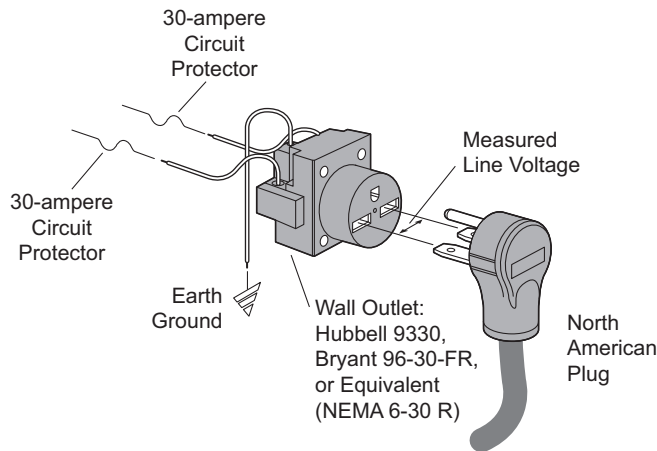

**Figure A.2** Electrical Connection



To ensure safety, the instrument should be wired to a remote emergency switch (preferably outside the room where the ultracentrifuge is housed, or adjacent to the exit from that room). In case of a malfunction, the centrifuge can be disconnected from the main power source by removing the Mains (power) plug from the outlet receptacle.

**Table A.1** Required Wire Connections

Wire Insulation Color	Terminal	Symbol	
		Harmonized	North American
Green/Yellow	Earth ground		
Light Blue	Neutral	N	L
Brown	Live or Line	L	L

## Attaching a Printer

A printer can be used with the Optima L-XP to print out run setups, programs, simulations, instrument logs, or run records. A Hewlett Packard Deskjet 940c printer (963423), available from Beckman Coulter, can be plugged into the parallel port on the back of the instrument control head (see [Figure A.3](#)).

**NOTE** The print driver for the Beckman Coulter supplied Deskjet 940c printer resides in the Optima L-XP eXPert software. If a different printer is used, the print driver will have to be installed by Beckman Coulter Field Service.

Figure A.3 Printer Connection

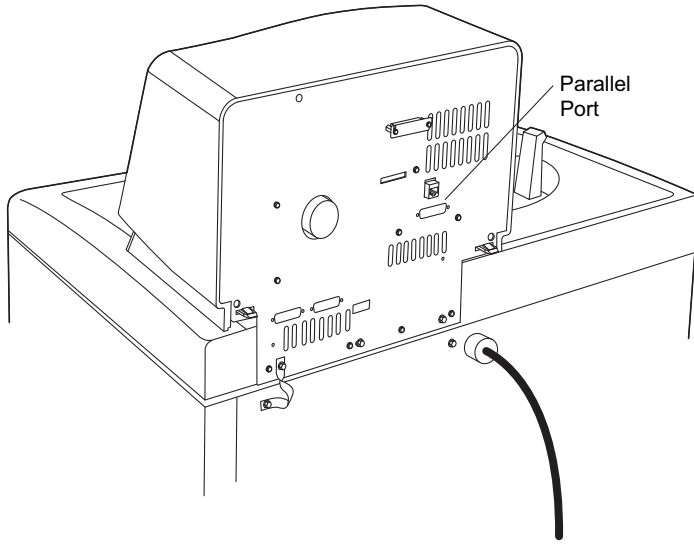

# Remote Access

## Introduction

---

*This appendix contains information on how to enable the use of the Remote Access feature.*

**NOTE** To enable the Remote Access feature, the ultracentrifuge must be connected to a Local Area Network (LAN) via the ethernet port.

The Remote Access feature provided with the Optima L-XP eXPert operating software allows for remote access and operation of the Optima L-XP ultracentrifuge using a computer running Virtual Networking Computing (VNC) software. Most of the VNC applications available for download are freeware and all are acceptable for use with the Optima L-XP eXPert operating software.

**NOTE** Technical support for the VNC software is not provided by Beckman Coulter Field Service. This appendix is intended to provide instructions on the use of the Optima L-XP eXPert operating software to enable a connection with the VNC client. Refer to the technical support policy for the VNC software in use.

Follow the directions provided with the VNC software for proper configuration. The Internet Protocol (IP) address of the Optima L-XP ultracentrifuge is needed to connect the VNC software to the ultracentrifuge. The IP address is obtained by using the following procedure.

### To enable remote access:

---

- 1 On the Settings screen, select **About Optima L-XP** from the Optima L-XP drop-down menu. The About Optima L-XP screen appears as shown in [Figure B.1](#).
- 2 From the About Optima L-XP screen, write down the IP address that is listed above the copyright disclaimer.
- 3 Press the **OK** button to close the About Optima L-XP screen.
- 4 Follow the directions provided with the VNC software to enter the IP address and to remotely access the ultracentrifuge.

Figure B.1 About Optima L-XP Screen



Once connected, the ultracentrifuge can be controlled using the computer's keyboard and mouse.

**NOTE** Two buttons on the control panel of the ultracentrifuge are mapped to the computer keyboard when using the Remote Access feature. The F7 key on the computer keyboard activates the Vacuum and the F8 key activates the Stop button. Some VNC software packages use the F8 key to display a menu. Consult the VNC software documentation for instructions to configure the F8 key or shift this menu command to a different key.

When finished using the ultracentrifuge, follow the directions provided with the VNC software to close the remote connection.

## VNC License Information

---

The Optima L-XP eXPert operating software contains VNC Free Edition 4.1.2 by RealVNC Ltd. VNC Free Edition is covered by the GNU General Public License, Version 2. VNC Free Edition 4.1.2 is redistributed within this product in unmodified binary form. Beckman Coulter, Inc. holds the source code for VNC Free Edition 4.1.2 as required by the GNU General Public License, Version 2, and provides said source code at no cost. To obtain a copy of the source code for VNC Free Edition 4.1.2 at no cost, please contact Beckman Coulter Technical Support.

Inclusion of VNC Free Edition 4.1.2 into the Optima L-XP ultracentrifuge is an aggregation as specified by the GNU General Public License, Version 2. As such, the GNU General Public License, Version 2, applies only to the VNC Free Edition components included with this ultracentrifuge.

## GNU General Public License, Version 2, June 1991

---

Copyright (C) 1989, 1991 Free Software Foundation, Inc. 59 Temple Place - Suite 330, Boston, MA 02111-1307, USA. Everyone is permitted to copy and distribute verbatim copies of this license document, but changing it is not allowed.

### Preamble

The licenses for most software are designed to take away your freedom to share and change it. By contrast, the GNU General Public License is intended to guarantee your freedom to share and change free software--to make sure the software is free for all its users. This General Public License applies to most of the Free Software Foundation's software and to any other program whose authors commit to using it. (Some other Free Software Foundation software is covered by the GNU Library General Public License instead.) You can apply it to your programs, too.

When we speak of free software, we are referring to freedom, not price. Our General Public Licenses are designed to make sure that you have the freedom to distribute copies of free software (and charge for this service if you wish), that you receive source code or can get it if you want it, that you can change the software or use pieces of it in new free programs; and that you know you can do these things.

To protect your rights, we need to make restrictions that forbid anyone to deny you these rights or to ask you to surrender the rights. These restrictions translate to certain responsibilities for you if you distribute copies of the software, or if you modify it.

For example, if you distribute copies of such a program, whether gratis or for a fee, you must give the recipients all the rights that you have. You must make sure that they, too, receive or can get the source code. And you must show them these terms so they know their rights.

We protect your rights with two steps: (1) copyright the software, and (2) offer you this license which gives you legal permission to copy, distribute and/or modify the software.

Also, for each author's protection and ours, we want to make certain that everyone understands that there is no warranty for this free software. If the software is modified by someone else and passed on, we want its recipients to know that what they have is not the original, so that any problems introduced by others will not reflect on the original authors' reputations.

Finally, any free program is threatened constantly by software patents. We wish to avoid the danger that redistributors of a free program will individually obtain patent licenses, in effect making the program proprietary. To prevent this, we have made it clear that any patent must be licensed for everyone's free use or not licensed at all.

The precise terms and conditions for copying, distribution and modification follow.

## GNU General Public License Terms and Conditions for Copying, Distribution and Modification

0. This License applies to any program or other work which contains a notice placed by the copyright holder saying it may be distributed under the terms of this General Public License. The “Program”, below, refers to any such program or work, and a “work based on the Program” means either the Program or any derivative work under copyright law: that is to say, a work containing the Program or a portion of it, either verbatim or with modifications and/or translated into another language. (Hereinafter, translation is included without limitation in the term “modification”.) Each licensee is addressed as “you”.
1. You may copy and distribute verbatim copies of the Program’s source code as you receive it, in any medium, provided that you conspicuously and appropriately publish on each copy an appropriate copyright notice and disclaimer of warranty; keep intact all the notices that refer to this License and to the absence of any warranty; and give any other recipients of the Program a copy of this License along with the Program. You may charge a fee for the physical act of transferring a copy, and you may at your option offer warranty protection in exchange for a fee.
2. You may modify your copy or copies of the Program or any portion of it, thus forming a work based on the Program, and copy and distribute such modifications or work under the terms of Section 1 above, provided that you also meet all of these conditions:
  - a. You must cause the modified files to carry prominent notices stating that you changed the files and the date of any change.
  - b. You must cause any work that you distribute or publish, that in whole or in part contains or is derived from the Program or any part thereof, to be licensed as a whole at no charge to all third parties under the terms of this License.
  - c. If the modified program normally reads commands interactively when run, you must cause it, when started running for such interactive use in the most ordinary way, to print or display an announcement including an appropriate copyright notice and a notice that there is no warranty (or else, saying that you provide a warranty) and that users may redistribute the program under these conditions, and telling the user how to view a copy of this License. (Exception: if the Program itself is interactive but does not normally print such an announcement, your work based on the Program is not required to print an announcement.

These requirements apply to the modified work as a whole. If identifiable sections of that work are not derived from the Program, and can be reasonably considered independent and separate works in themselves, then this License, and its terms, do not apply to those sections when you distribute them as separate works. But when you distribute the same sections as part of a whole which is a work based on the Program, the distribution of the whole must be on the terms of this License, whose permissions for other licensees extend to the entire whole, and thus to each and every part regardless of who wrote it.

Thus, it is not the intent of this section to claim rights or contest your rights to work written entirely by you; rather, the intent is to exercise the right to control the distribution of derivative or collective works based on the Program.

In addition, mere aggregation of another work not based on the Program with the Program (or with a work based on the Program) on a volume of a storage or distribution medium does not bring the other work under the scope of this License.

3. You may copy and distribute the Program (or a work based on it, under Section 2) in object code or executable form under the terms of Sections 1 and 2 above provided that you also do one of the following:
  - a. Accompany it with the complete corresponding machine-readable source code, which must be distributed under the terms of Sections 1 and 2 above on a medium customarily used for software interchange; or,
  - b. Accompany it with a written offer, valid for at least three years, to give any third party, for a charge no more than your cost of physically performing source distribution, a complete machine-readable copy of the corresponding source code, to be distributed under the terms of Sections 1 and 2 above on a medium customarily used for software interchange; or,
  - c. Accompany it with the information you received as to the offer to distribute corresponding source code. (This alternative is allowed only for noncommercial distribution and only if you received the program in object code or executable form with such an offer, in accord with Subsection b above.)

The source code for a work means the preferred form of the work for making modifications to it. For an executable work, complete source code means all the source code for all modules it contains, plus any associated interface definition files, plus the scripts used to control compilation and installation of the executable. However, as a special exception, the source code distributed need not include anything that is normally distributed (in either source or binary form) with the major components (compiler, kernel, and so on) of the operating system on which the executable runs, unless that component itself accompanies the executable.

If distribution of executable or object code is made by offering access to copy from a designated place, then offering equivalent access to copy the source code from the same place counts as distribution of the source code, even though third parties are not compelled to copy the source along with the object code.

4. You may not copy, modify, sublicense, or distribute the Program except as expressly provided under this License. Any attempt otherwise to copy, modify, sublicense or distribute the Program is void, and will automatically terminate your rights under this License. However, parties who have received copies, or rights, from you under this License will not have their licenses terminated so long as such parties remain in full compliance.
5. You are not required to accept this License, since you have not signed it. However, nothing else grants you permission to modify or distribute the Program or its derivative works. These actions are prohibited by law if you do not accept this License. Therefore, by modifying or distributing the Program (or any work based on the Program), you indicate your acceptance of this License to do so, and all its terms and conditions for copying, distributing or modifying the Program or works based on it.
6. Each time you redistribute the Program (or any work based on the Program), the recipient automatically receives a license from the original licensor to copy, distribute or modify the Program subject to these terms and conditions. You may not impose any further restrictions on the recipients' exercise of the rights granted herein. You are not responsible for enforcing compliance by third parties to this License.
7. If, as a consequence of a court judgment or allegation of patent infringement or for any other reason (not limited to patent issues), conditions are imposed on you (whether by court order, agreement or otherwise) that contradict the conditions of this License, they do not excuse you from the conditions of this License. If you cannot distribute so as to satisfy simultaneously your obligations under this License and any other pertinent obligations, then as a consequence you

may not distribute the Program at all. For example, if a patent license would not permit royalty-free redistribution of the Program by all those who receive copies directly or indirectly through you, then the only way you could satisfy both it and this License would be to refrain entirely from distribution of the Program.

If any portion of this section is held invalid or unenforceable under any particular circumstance, the balance of the section is intended to apply and the section as a whole is intended to apply in other circumstances.

It is not the purpose of this section to induce you to infringe any patents or other property right claims or to contest validity of any such claims; this section has the sole purpose of protecting the integrity of the free software distribution system, which is implemented by public license practices. Many people have made generous contributions to the wide range of software distributed through that system in reliance on consistent application of that system; it is up to the author/donor to decide if he or she is willing to distribute software through any other system and a licensee cannot impose that choice.

This section is intended to make thoroughly clear what is believed to be a consequence of the rest of this License.

8. If the distribution and/or use of the Program is restricted in certain countries either by patents or by copyrighted interfaces, the original copyright holder who places the Program under this License may add an explicit geographical distribution limitation excluding those countries, so that distribution is permitted only in or among countries not thus excluded. In such case, this License incorporates the limitation as if written in the body of this License.
9. The Free Software Foundation may publish revised and/or new versions of the General Public License from time to time. Such new versions will be similar in spirit to the present version, but may differ in detail to address new problems or concerns.

Each version is given a distinguishing version number. If the Program specifies a version number of this License which applies to it and “any later version”, you have the option of following the terms and conditions either of that version or of any later version published by the Free Software Foundation. If the Program does not specify a version number of this License, you may choose any version ever published by the Free Software Foundation.

10. If you wish to incorporate parts of the Program into other free programs whose distribution conditions are different, write to the author to ask for permission. For software which is copyrighted by the Free Software Foundation, write to the Free Software Foundation; we sometimes make exceptions for this. Our decision will be guided by the two goals of preserving the free status of all derivatives of our free software and of promoting the sharing and reuse of software generally.



**NO WARRANTY**

11. BECAUSE THE PROGRAM IS LICENSED FREE OF CHARGE, THERE IS NO WARRANTY FOR THE PROGRAM, TO THE EXTENT PERMITTED BY APPLICABLE LAW. EXCEPT WHEN OTHERWISE STATED IN WRITING THE COPYRIGHT HOLDERS AND/OR OTHER PARTIES PROVIDE THE PROGRAM "AS IS" WITHOUT WARRANTY OF ANY KIND, EITHER EXPRESSED OR IMPLIED, INCLUDING, BUT NOT LIMITED TO, THE IMPLIED WARRANTIES OF MERCHANTABILITY AND FITNESS FOR A PARTICULAR PURPOSE. THE ENTIRE RISK AS TO THE QUALITY AND PERFORMANCE OF THE PROGRAM IS WITH YOU. SHOULD THE PROGRAM PROVE DEFECTIVE, YOU ASSUME THE COST OF ALL NECESSARY SERVICING, REPAIR OR CORRECTION.
12. IN NO EVENT UNLESS REQUIRED BY APPLICABLE LAW OR AGREED TO IN WRITING WILL ANY COPYRIGHT HOLDER, OR ANY OTHER PARTY WHO MAY MODIFY AND/OR REDISTRIBUTE THE PROGRAM AS PERMITTED ABOVE, BE LIABLE TO YOU FOR DAMAGES, INCLUDING ANY GENERAL, SPECIAL, INCIDENTAL OR CONSEQUENTIAL DAMAGES ARISING OUT OF THE USE OR INABILITY TO USE THE PROGRAM (INCLUDING BUT NOT LIMITED TO LOSS OF DATA OR DATA BEING RENDERED INACCURATE OR LOSSES SUSTAINED BY YOU OR THIRD PARTIES OR A FAILURE OF THE PROGRAM TO OPERATE WITH ANY OTHER PROGRAMS), EVEN IF SUCH HOLDER OR OTHER PARTY HAS BEEN ADVISED OF THE POSSIBILITY OF SUCH DAMAGES.

**END OF TERMS AND CONDITIONS**



# Beckman Coulter, Inc. Optima L, LE, L-XP, and XL Preparative Ultracentrifuges Warranty

Subject to the exceptions and upon the conditions specified below, Beckman Coulter, Inc., agrees to correct, either by repair, or, at its election, by replacement, any defects of material or workmanship which develop within one (1) year after delivery of the Optima Ultracentrifuge (the product), to the original Buyer by Beckman Coulter, or by an authorized representative, provided that investigation and factory inspection by Beckman Coulter discloses that such defect developed under normal and proper use.

Some components and accessories by their nature are not intended to and will not function for as long as one (1) year. If any such component or accessory fails to give reasonable service for a reasonable period of time, Beckman Coulter will repair or, at its election, replace such component or accessory. What constitutes either reasonable service and a reasonable period of time shall be determined solely by Beckman Coulter.

## **Replacement**

Any product claimed to be defective must, if requested by Beckman Coulter be returned to the factory, transportation charges prepaid, and will be returned to Buyer with the transportation charges collect unless the product is found to be defective, in which case Beckman Coulter will pay all transportation charges.

Beckman Coulter makes no warranty concerning products or accessories not manufactured by it. In the event of failure of any such product or accessory, Beckman Coulter will give reasonable assistance to the Buyer in obtaining from the respective manufacturer whatever adjustment is reasonable in light of the manufacturer's own warranty.

Damage to the instrument while operating a rotor not of Beckman Coulter manufacture is not covered by warranty or service contract terms. Further, Beckman Coulter shall be released from all obligations under all warranties either expressed or implied, if the product covered hereby is repaired or modified by persons other than its own authorized service personnel, unless such repair is made by others who meet qualifications similar to those required of Beckman Coulter's service personnel, or unless such repair in the sole opinion of Beckman Coulter is minor, or unless such modification is merely the installation of a new Beckman Coulter plug-in component for such product.

## **Special Drive Warranty**

During the instrument warranty period (one year), there will be no charge for drive replacement if the drive unit is installed, serviced, and operated in accordance with the conditions listed below. During the drive's second through tenth year of use there is a prorated drive replacement price based on years of use if the drive unit is installed, serviced, and operated in accordance with the conditions listed below.

Drive replacement price for units not under service contract\* = current drive exchange price  
 $\infty \left\langle \frac{\text{years of use}}{10} \right\rangle + \text{labor and travel.}$

---

\* For details of drive coverage with a service contract, contact your local Beckman Coulter service representative.

### **Conditions**

1. The drive has been operated only within its rated speed and temperature ranges.
2. The drive unit has not been subjected to unequal loading, improper rotor installation, corrosion from material spilled onto the hub or accumulated in the chamber of the instrument.
3. The drive unit has not been disassembled, modified, or repaired, except by Beckman Coulter personnel.
4. The drive unit was installed by a Beckman Coulter Field Service representative.
5. The instrument in which the drive unit has been used and operated, and its associated rotors, were manufactured by Beckman Coulter and serviced only by Beckman Coulter Field Service representatives.

If the above conditions are not met, the full appropriate exchange price for the drive will be charged.

### **Disclaimer**

IT IS EXPRESSLY AGREED THAT THE ABOVE WARRANTY SHALL BE IN LIEU OF ALL WARRANTIES OF FITNESS AND OF THE WARRANTY OF MERCHANTABILITY AND THAT BECKMAN COULTER, INC. SHALL HAVE NO LIABILITY FOR SPECIAL OR CONSEQUENTIAL DAMAGES OF ANY KIND WHATSOEVER ARISING OUT OF THE MANUFACTURE, USE, SALE, HANDLING, REPAIR, MAINTENANCE, OR REPLACEMENT OF THE PRODUCT.

Symbol Symbol Simbolo Symbole Simbolo	Simbole СИМВОЛ 符号 記号 상징	Title / Titel / Titolo / Titre / Titolo / Titolo / Название / 标题 / タイトル / 제목	
		Dangerous voltage Gefährliche elektrische Spannung Voltaje peligroso Courant haute tension Pericolo: alta tensione	Tensão perigosa Опасное напряжение тока 危険电压 危険な電圧 위험한 전압
		Caution, consult accompanying documents Vorsicht, konsultieren Begleitdokumente Atención, consulta documentos adjuntos Attention, consultez des documents d'accompagnement Attenzione, consulta i documenti di accompagnamento	Cuidado, consulte documentos adjuntos Внимание, советует с сопроводительными документами 注意, 咨询附属单证 注意, 伴う文書に相談しなさい 주의, 동반 문서를 상담하십시오
		Biohazard Potentiell infektiösem Material Riesgo biológico Risque biologique Pericolo biologico	Material infeccioso potencial биологической опасности 可能的传染性物 潜在的な感染性物質 전염하는 물자
		On (power) Ein (Netzverbindung) Encendido Marche (mise sous tension) Acceso (sotto tensione)	Fora (o poder) На (мощности) 开 (电源) ン (電源) 에 (힘)
		Off (power) Aus (Netzverbindung) Apagado Arrêt (mise sous tension) Spento (fuori tensione)	Fora de (poder) С (сила) (电源) ン (電源) 떨어져 (힘)
		Protective earth (ground) Schutzleiteranschluß Puesta a tierra de protección Liaison à la terre Collegamento di protezione a terra	Terra de proteção (terra) Защитное заземление (земля) 保护接地 保護アース (接地) 방어적인 지구 (지상)
		Earth (ground) Erde (Masse) La tierra (suelo) Terre (sol) Scarica a terra	Terra Земли 接地 アース (接地) 지구 (지상)
		Manufacturer Hersteller Fabricante Fabricant Fabbicante	Fabricante производитель 制造商 メーカー 제조자
		Consult Instructions for Use Konsultieren Sie Anwendungsvorschriften Consulte las instrucciones para el uso Consultez les instructions pour l'usage Consulti le istruzioni per uso	Consulte instruções para o uso Советуйте с инструкциями для пользы 咨询使用说明书 使用説明に相談しなさい 사용 설명을 상담하십시오

## Related Documents

### **Rotors & Tubes for Beckman Coulter Preparative Ultracentrifuges**

PN LR-IM-24

- Rotors
- Tubes, Bottles, and Accessories
- Using Tubes, Bottles, and Accessories
- Using Fixed-Angle Rotors
- Using Swinging-Bucket Rotors
- Using Vertical-Tube and Near-Vertical Tube rotors
- Care and Maintenance
- Chemical Resistances
- Using the w2t Integrator
- The Use of Cesium Chloride Curves
- Gradient Materials
- References
- Glossary

Available in electronic pdf or CD-ROM by request.

### **Chemical Resistances for Beckman Coulter Centrifugation Products**

PN IN-175

Available in hard copy or electronic pdf by request.

Available at  
[www.beckmancoulter.com](http://www.beckmancoulter.com)

### **Ultracentrifuge Rotors, Tubes, & Accessories Catalog**

PN BR-8101

Available in hard copy or electronic pdf by request.

Available at  
[www.beckmancoulter.com](http://www.beckmancoulter.com)

[www.beckmancoulter.com](http://www.beckmancoulter.com)

